

**WEST CREEK PARK AND BIKE TRAIL**  
**TRANSFER AGREEMENT TO**  
**CITY OF SANTA CLARITA**

This Santa Clarita Park Property Transfer Agreement (“Agreement”) is made and entered into this \_ \_\_\_ day of \_\_\_\_\_2016, by and between the City of Santa Clarita, a municipal corporation (“City”), and the County of Los Angeles (“County”) a body politic and corporate, pursuant to Government Code Section 25550.5, regarding the conveyance of real properties. This Agreement is made with reference to the following facts:

- A. County is the owner of a 16.88 acre, individual park property known as West Creek Park (the " Park"), as shown on the grant deed recorded on January 14, 2010, attached hereto and incorporated herein by this reference as Exhibit A (the "Grant Deed"). Said Park Property is comprised of 2.528 acres of parkland that the County owns in fee, in addition to 14.355 acres of parkland that is owned by the Metropolitan Water District of Southern California, a public corporation (“MWD”) who granted an easement for park purposes to Newhall Land and Farming on June 12, 2007, who subsequently assigned their park easement right to the County through an assignment agreement (“Assignment”). Said Assignment to the County was recorded on January 14, 2010 attached hereto and incorporated herein by this reference as Exhibit A-1. The real property being conveyed shall be referred to collectively herein as the “Park Property.”
- B. County is the owner of an easement granted to the County by Newhall Land and Farming that is used by the general public as a Class 1 Bike Trail (“Bike Trail”). Said Bike Trail was recorded on March 31, 2011 attached hereto and incorporated herein by this reference as Exhibit B. The Bike Trail currently runs over property owned by Newhall Land and Farming (“Newhall”)
- C. City agrees to accept the Park Property and Bike Trail for the purpose of incorporating them into the City’s park and trail system.

NOW, THEREFORE, in consideration of the promises, conditions, and mutual covenants set forth herein, the parties hereto do agree as follows:

**1. Transfer of Park Property.**

A. Fee-owned portion of the Park. County agrees to effectuate the transfer of the County-owned portion of the Park Property by executing the Quitclaim Deed, attached hereto and incorporated herein by this reference, as Exhibit C. City hereby warrants to County that said Quitclaim Deed is sufficient to release County’s interest in the County’s fee-owned portion of the Park and City agrees to accept County’s Quitclaim Deed for the County’s fee-owned portion of the Park.

B. MWD-owned portion of the Park. County agrees to quitclaim its existing easement for park purposes over the MWD-owned portion of the Park by executing the Quitclaim Deed, attached hereto and incorporated herein by this reference, as Exhibit D, subject to the acceptance of the quitclaim deed by MWD. City agrees to enter into an agreement with MWD that would allow the City to accept an easement for park purposes over the MWD-owned portion of the Park similar to the attached Exhibit E, incorporated herein by this reference, to be granted to the City by MWD.

**2. Transfer of Bike Trail Easement.** County agrees to effectuate the transfer of the Bike Trail by executing the Quitclaim Easement Deed attached hereto and incorporated herein by this reference as Exhibit F, thereby quitclaiming the County's existing bike trail easement with said quitclaim easement deed to be accepted by Newhall. The City agrees to enter into an agreement with Newhall that will allow the City to accept a Class 1 bike trail easement similar to the attached Exhibit G, incorporated herein by this reference, to be granted to the City by Newhall.

**3. Use.** The City agrees at its cost to develop, operate and maintain the Park Property and Bike Trail solely for public park, trail, and recreational purposes.

**4. Consideration.** Both City and County mutually agree that the consideration provided for the conveyance of the Park Property shall be the City's agreement to develop, operate, and maintain the Park Property and Bike Trail for open space, public park, and recreational purposes for the benefit of the residents of incorporated and unincorporated Los Angeles County.

**5. Condition of Title to Park Property.** Except as otherwise expressly provided in this Agreement, the City is acquiring the Park Property "AS IS" and "WITH ALL FAULTS" in their present state and conditions as of the Closing. Except for the express representations and warranties set forth herein, each party agrees that the other has not made, does not make and specifically negates and disclaims any representations or warranties of any kind or character whatsoever, whether express or implied, oral or written, past, present or future, of, as to, concerning or with respect to the property being conveyed by it hereunder (including, without limitation, any warranty of merchantability, habitability, or fitness for a particular purpose).

**6. Warranties of County.** County warrants that:

A. County has no actual present knowledge of any pending litigation involving the Park Property.

B. County has no actual present knowledge of any violation of, or notices concerning defects or noncompliance with, any applicable building code or other code, statute, regulation, ordinance, judicial order, or judicial holding pertaining to the Park Property.

**7. Closing Date and Recordation.** The closing date ("Closing Date") shall occur in conjunction with the City completing its official annexation of the Park Property

Draft

into the City's borders (the "West Creek/West Hills Annexation"), anticipated to occur on \_\_\_\_\_, 2016.

The parties agree that the County will arrange for recording of the documents necessary to complete the conveyance contemplated hereby. The City agrees to timely provide the County its certificate(s) or resolution(s) of acceptance, pursuant to Government Code Section 27281, prior to the recording of the documents in a form substantially similar to that shown in Exhibit H, attached hereto and incorporated herein by this reference.

**8. Indemnification.** The City waives any and all claims, and agrees to indemnify, defend, save, and hold harmless County and its Special Districts, elected and appointed officers, employees, and agents (collectively, "County Indemnified Parties"), from and against any and all liability, expense (including without limitation defense costs and legal fees), and claims for damages of any nature whatsoever, related to site conditions of the Park Property that accrue, or incidents that occur, after the Closing Date.

**9. Default Regarding Use of County Lobbyists.** State and each County Lobbyist or County Lobbying firm, as defined in Los Angeles County Code Section 2.160.010, retained by State shall fully comply with the County Lobbyist Ordinance, Los Angeles County Code 2.160. Failure on the part of State or any County Lobbyist or County Lobbying firm retained by State to fully comply with the County Lobbyist Ordinance shall constitute a material breach of this Agreement upon which County may immediately terminate or suspend this Agreement.

**10. Notices.** Any written notices required by this Agreement shall be made by personal delivery, registered or certified mail, postage prepaid, to the address indicated below:

City: Darren Hernandez  
Deputy City Manager  
City of Santa Clarita  
23920 Valencia Boulevard, Suite 230  
Santa Clarita, CA 91355

with a copy to: City Clerk  
City of Santa Clarita  
23920 Valencia Boulevard  
Santa Clarita, CA 91355

County: Chief Executive Office  
500 W. Temple Street, Room 754  
Los Angeles, CA 90012  
ATTENTION: Christopher M. Montana  
Director of Real Estate Division

with a copy to: Department of Parks and Recreation

Attention: Kathline King, Planning Division  
510 South Vermont Avenue  
Los Angeles, CA 90020

11. **Counterpart.** This Agreement may be executed in multiple counterparts, each of which shall be deemed an original, but of which, together, shall constitute one and the same instrument.

12. **Authorization, Approvals, Binding Nature.** This Agreement has no force and effect and is not binding on the City until and unless it is authorized by the City Council, and is not binding on the County until and unless authorized by the Board of Supervisors at a duly noticed public meeting.

13. **Time is of the Essence.** Time is of the essence for each and every term, condition, covenant, obligation and provision of this Agreement.

14. **Severability.** In the event any portion of this Agreement shall be declared by any court of competent jurisdiction to be invalid, illegal, or unenforceable, such portion shall be severed from the Agreement, and the remaining parts hereof shall remain in full force and effect as fully as though such invalid, illegal, or unenforceable portion had never been part of the Agreement, provided the remaining Agreement can be reasonably and equitably enforced.

15. **Binding on Successors.** Subject to the limitations set forth herein, the Agreement shall be binding upon and inure to the benefit of the successors and assigns of the respective parties hereto.

16. **California Law.** This Agreement shall be construed in accordance with the internal laws of the State of California.

17. **Waivers.** No waiver by either party of any provision hereof shall be deemed a waiver of any other provision hereof or of any subsequent breach by either party of the same or any other provision.

18. **Captions.** The captions and the section and subsection numbers appearing in this Agreement are inserted only as a matter of convenience and in no way define, limit, construe or describe the scope or intent of such sections of this Agreement nor in any way affect this Agreement.

19. **No Presumption Re: Drafter.** The parties acknowledge and agree that the terms and provisions of this Agreement have been negotiated and discussed between the parties and their attorneys, and this Agreement reflects their mutual agreement regarding the same. Because of the nature of such negotiations and discussions, it would be inappropriate to deem any party to be the drafter of this Agreement, and therefore, no presumption for or against validity or as to any interpretation hereof, based upon the identity of the drafter, shall be applicable in interpreting or enforcing this Agreement.

**20. Assistance of Counsel.** Each party hereto either had the assistance of counsel or had counsel available to it, in the negotiation for, and the execution of, this Agreement, and all related documents.

**21. Required Actions of the Parties.** County and City agree to execute all such instruments and documents and to take all action as may be required in order to consummate the purchase and sale herein contemplated.

**22. Survival of Covenants.** The covenants, agreements, representations and warranties made herein are intended to survive the consummation of the transfer of the Park Property and recordation of the Quitclaim Deeds.

**23. Interpretation.** Unless the context of this Agreement clearly requires otherwise: (i) the plural and singular numbers shall be deemed to include the other; (ii) the masculine, feminine and neuter genders shall be deemed to include the others; (iii) "or" is not exclusive; and (iv) "includes" and "including" are not limiting.

**24. Final Agreement.** This Agreement and the exhibits attached hereto, contains the entire agreement of the parties with respect to the transaction contemplated hereby and supersedes any prior agreement, oral or written, between City and County, about the subject matter hereof. No contemporaneous or subsequent agreement, amendment, representation or promise made by either party hereto, or by or to any employee, officer, agent, or representative of either party, shall be of any effect unless it is in writing and executed by the parties hereto.

(SIGNATURE PAGE FOLLOWS)

Draft

IN WITNESS WHEREOF, the parties hereto have caused this Agreement to be executed and attested by their duly authorized officials, as of the day and year first above written.

**CITY OF SANTA CLARITA**

A municipal corporation

BY: \_\_\_\_\_

Kenneth W. Striplin  
City Manager

ATTEST:

BY: \_\_\_\_\_

Kevin Tonoian  
City Clerk

APPROVED AS TO FORM:

BY: \_\_\_\_\_

Joseph M. Montes  
City Attorney

**COUNTY OF LOS ANGELES**

By \_\_\_\_\_

Chair, Board of Supervisors

ATTEST:

Lori Glasgow  
Executive Officer- Clerk of  
The Board of Supervisors

By: \_\_\_\_\_

Deputy

APPROVED AS TO FORM:

MARY C. WICKHAM  
County Counsel

By: \_\_\_\_\_

Deputy

**TRANSFER AGREEMENT EXHIBITS TABLE OF CONTENTS**

EXHIBIT A – Recorded Vesting Deed for County-Owned Portion of West Creek Park

EXHIBIT A-1 – Recorded Assignment Agreement for MWD-Owned Portion of West Creek Park

EXHIBIT B - Recorded Bike Trail Easement from Newhall to County

EXHIBIT C – County Quitclaim Deed to City for County-Owned Portion of West Creek Park

EXHIBIT D – County Quitclaim Deed to MWD for MWD-Owned Portion of West Creek Park

EXHIBIT E – MWD Easement to City for MWD-Owned Portion of West Creek Park (*To Be Drafted*)

EXHIBIT F – County Quitclaim Deed for Bike Trail Easement to Newhall

EXHIBIT G – Newhall Easement to City For Bike Trail Easement (*To Be Drafted*)

EXHIBIT H – City Certificate of Acceptance

# EXHIBIT A

RECORDING REQUESTED BY:

Newhall Land  
23823 Valencia Blvd.  
Valencia, CA 91381  
Attention; Fred MacMurdo

WHEN RECORDED MAIL TO:

County of Los Angeles  
Department of Public Works  
P.O. Box 1460  
Alhambra, CA 91802-1460  
Attn: Mapping & Property Management Div.  
Title & Escrow Section  
Alan R. Husted

**COPY** of Document Recorded  
on 1/14/10 as No. 0059019  
Has not been compared with original.  
**Los Angeles** COUNTY RECORDER

Recording Fee: Exempt  
(Government Code Section 27383)

Space above this line for Recorder's use

Documentary Transfer Tax: Exempt  
(Revenue and Taxation Code Section 11922)

TRACT 52455-01 LOT 367  
and 391 (ALL)

TITLE (S)

GRANT DEED

THIS INSTRUMENT FILED FOR RECORD BY FIRST AMERICAN  
TITLE CO. AS AN ACCOMMODATION ONLY. IT HAS NOT  
BEEN EXAMINED AS TO ITS EXECUTION OR AS TO ITS  
EFFECT UPON TITLE.



RECORDING REQUESTED BY:

Newhall Land  
23823 Valencia Blvd.  
Valencia, CA 91381  
Attention: Fred MacMurdo

WHEN RECORDED MAIL TO AND  
MAIL TAX STATEMENTS TO:

COUNTY OF LOS ANGELES  
Department of Public Works  
P.O. Box 1460  
Alhambra, CA 91802-1460  
Attn: Mapping & Property Management Division  
Title & Escrow Section  
Alan R. Husted

---

(Space Above for Recorder's Use)

TRACT 52455-01 LOTS 367 & 391  
APNS: 2810-110-008 and 2810-105-045

**GRANT DEED**

No Documentary Transfer Tax due. The County of Los Angeles is acquiring title and this transfer is therefor exempt from Documentary Transfer Tax pursuant to Cal. Revenue and Taxation Code Section 11922.

FOR GOOD AND VALUABLE CONSIDERATION, the receipt and sufficiency of which is hereby acknowledged, THE NEWHALL LAND AND FARMING COMPANY (A CALIFORNIA LIMITED PARTNERSHIP), a California limited partnership ("Grantor"), hereby grants to the County of Los Angeles, a body corporate and politic ("Grantee"), that certain real property (the "Property") for public park purposes, located in the County of Los Angeles, State of California, legally described in the attached Exhibit "A" and depicted in Exhibit "B". Exhibit "A" and Exhibit "B" are incorporated herein by this reference.

The Property being conveyed to the County of Los Angeles for public park purposes comprises 2.528 acres and was amended from its previous designation on the map of Tract No. 52455-01, filed in Book 1323, page(s) 43 through 73, inclusive, of Maps, in the office of the Registrar-Recorder/County Clerk of the County of Los Angeles pursuant to that Certificate of Correction recorded on May 21, 2009, in the official records of Los Angeles County as Instrument No. 20090758065.

Said Certificate of Correction amended Lot 367, previously designated on Sheet 18 of said Tract as a RECREATION lot to a PUBLIC PARK designation, and Lot 391,

previously designated as an OPEN SPACE lot on Sheet 13 of said Tract, was amended to a PUBLIC PARK designation pursuant to said Certificate of Correction.

EXCEPTING AND RESERVING UNTO GRANTOR, its successors and assigns, together with the right to grant and transfer all or a portion of the same, as follows:

A. All oil, oil rights, minerals, mineral rights, natural gas rights and other hydrocarbons by whatsoever name known, geothermal steam and all products derived from any of the foregoing, that may be within or under the Property, together with the perpetual right of drilling, mining, exploring and operating therefor and storing in and removing the same from the Property or any other property, including the right to whipstock or directionally drill and mine from properties other than the Property, oil or gas wells, tunnels and shafts into, through or across the subsurface of the Property, and to bottom such whipstocked or directionally drilled wells, tunnels and shafts under and beneath or beyond the exterior limits thereof, and to redrill, retunnel, equip, maintain, repair, deepen and operate any such wells or mines without, however, the right to drill, mine, store, explore or operate through the surface of the Property or the upper 500 feet of the subsurface of the Property for such substances.

B. All water and water rights and interests now or in the future owned by Grantor or in any way appurtenant or related to the Property or used by Grantor in connection with or related to the Property (no matter how acquired by Grantor), together with the right and power to explore, drill, redrill, remove and store the same from, under or in the Property or to divert or otherwise utilize such water rights or interests on any other property owned, leased or designated by Grantor, and the right and power to conduct water over or through the Property and to store water underneath the Property by such means as Grantor deems reasonable; but without, however, any rights in any surface waters or any right to enter upon the surface of the Property or upper fifty (50) feet of the subsurface of the Property in the exercise of the rights reserved to Grantor in this paragraph B. Except as otherwise expressly provided herein, the water and water rights excepted from this deed and reserved to the Grantor include, but are not limited to, all riparian water rights, all appropriative water rights, all water rights and rights to store water in subsurface reservoirs based on overlying land ownership, all littoral water rights, all rights to percolating water, all prescriptive water rights, all adjudicated, statutory or contractual water rights, all rights to aquifers, subsurface reservoirs and subsurface waters, and all rights to take, use and develop for use any and all water that may now exist or may in the future exist upon, in or under the Property. Without limiting any of the reservations in this section, it is the intent of Grantor herein to reserve and except from the conveyance pursuant to this deed all of Grantor's water rights except as otherwise provided herein. To the maximum extent permitted by law, Grantor and Grantee, by making and accepting this grant, agree that Grantee cannot obtain any of Grantor's water rights in contravention of this deed. Accordingly, if a court or public agency determines that Grantee received any of Grantor's water rights related to the Property by virtue of the subject transaction or Grantee's ownership of the Property, Grantee hereby quitclaims to Grantor all such water rights, and Grantee shall also execute such further documentation as Grantor shall reasonably request to further memorialize such quitclaim.

No failure to exercise or delay in the exercise of any of Grantor's rights reserved in or excepted from this deed shall impair or limit such right or be construed as a waiver of such right. Without limiting any other provision of this deed, Grantee shall not take or attempt to take any water or water rights (i) now or in the future owned by Grantor, or (ii) appurtenant to or related in any way to the Property. Grantee shall not explore, drill or redrill on the Property to remove or store any water from, under or in the Property.

THIS GRANT AND CONVEYANCE IS MADE AND ACCEPTED SUBJECT TO:

1. All nondelinquent general, special and supplemental real property taxes and assessments.

2. All other covenants, conditions, restrictions, reservations, rights, rights-of-way, dedications, offers of dedication, encumbrances, equitable servitudes, easements and other matters of record or otherwise known to Grantee as of the date hereof.

[signature page follows]

IN WITNESS WHEREOF, the Grantor has executed this deed as of the date written below.

Dated: January 6, 2010

**GRANTOR:**

THE NEWHALL LAND AND FARMING COMPANY (A CALIFORNIA LIMITED PARTNERSHIP), a California limited partnership

By: NWHL GP LLC, a Delaware limited liability company, its General Partner

By: LandSource Holding Company, LLC, a Delaware limited liability company, its Sole Member

By: Newhall Land Development, LLC, a Delaware limited liability company, its Sole Member

By: Newhall Holding Company, LLC, a Delaware limited liability company, its Manager

*ZM* By:   
Name: STEVEN D. ZIMMER  
Executive Vice President  
Title: \_\_\_\_\_

By:  1/6/10  
Name: MARK SUBBOTIN  
Title: Vice President

**CALIFORNIA ALL-PURPOSE ACKNOWLEDGEMENT**

STATE OF CALIFORNIA                                 )  
   )       S.S.  
COUNTY OF LOS ANGELES

C.

On January 6, 2010 before me JOHANNA PALMER,  
Notary Public, personally appeared STEVEN D. ZIMMER AND MARK SUBBITIN  
who proved to me on the basis of satisfactory evidence to be the person(s) whose name(s)  
is/are subscribed to the within instrument and acknowledged to me that he/she/they  
executed the same in his/her/their authorized capacity(ies), and that by his/her/their  
signature(s) on the instrument the person(s), or the entity upon behalf of which the  
person(s) acted, executed the instrument.

I certify under PENALTY OF PERJURY under the laws of the State of California  
that the foregoing paragraph is true and correct.

WITNESS my hand and official seal.

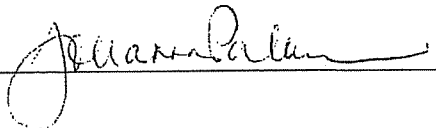
Signature  (Seal)

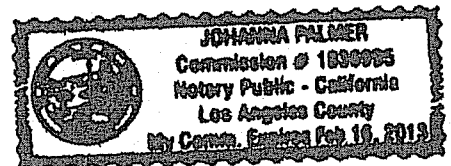

**CERTIFICATE OF ACCEPTANCE**

This is to certify that the interest in real property conveyed by the attached Grant Deed to the County of Los Angeles is hereby accepted under the authority delegated to the Los Angeles County Chief Executive Office pursuant to Section 2.08.168 of the County Code and consents to the recordation thereof by its duly authorized officer.

By: William L. Dawson  
William L. Dawson  
Director of Real Estate  
Chief Executive Office  
County of Los Angeles

Date: Jan. 11, 2010

**PUBLIC AGENCY CERTIFICATE OF ACKNOWLEDGEMENT (CC 1190)**

State of California )  
 ) SS.  
County of Los Angeles )

On 11<sup>th</sup> day of January 2010, before me, **DEAN C. LOGAN**, Acting Registrar-Recorder/County Clerk of the County of Los Angeles, personally appeared William L. Dawson, who proved to me on the basis of satisfactory evidence to be the person whose name is subscribed to the within instrument and acknowledged to me that he executed the same in his authorized capacity, and that by his signature on the instrument the person, or the entity upon behalf of which the person acted, executed the instrument.

I certify under PENALTY OF PERJURY under the laws of the State of California that the foregoing paragraph is true and correct.

IN WITNESS WHEREOF, I have hereunto set my hand and affixed the seal the day and year in this Certificate of Acknowledgement first written above.

DEAN C. LOGAN

Registrar-Recorder/County Clerk

By: Christopher M. Montana  
Christopher M. Montana  
Deputy



EXHIBIT "A"

Legal Description

That certain real property situated in the State of California, County of Los Angeles, and described as follows:

Lots 367 and 391 of Tract No. 52455-01, in the County of Los Angeles, State of California, as per map recorded in Book 1323, Pages 43 to 73 inclusive of Maps, in the Office of the County Recorder of said County.

EXHIBIT "B"

2010

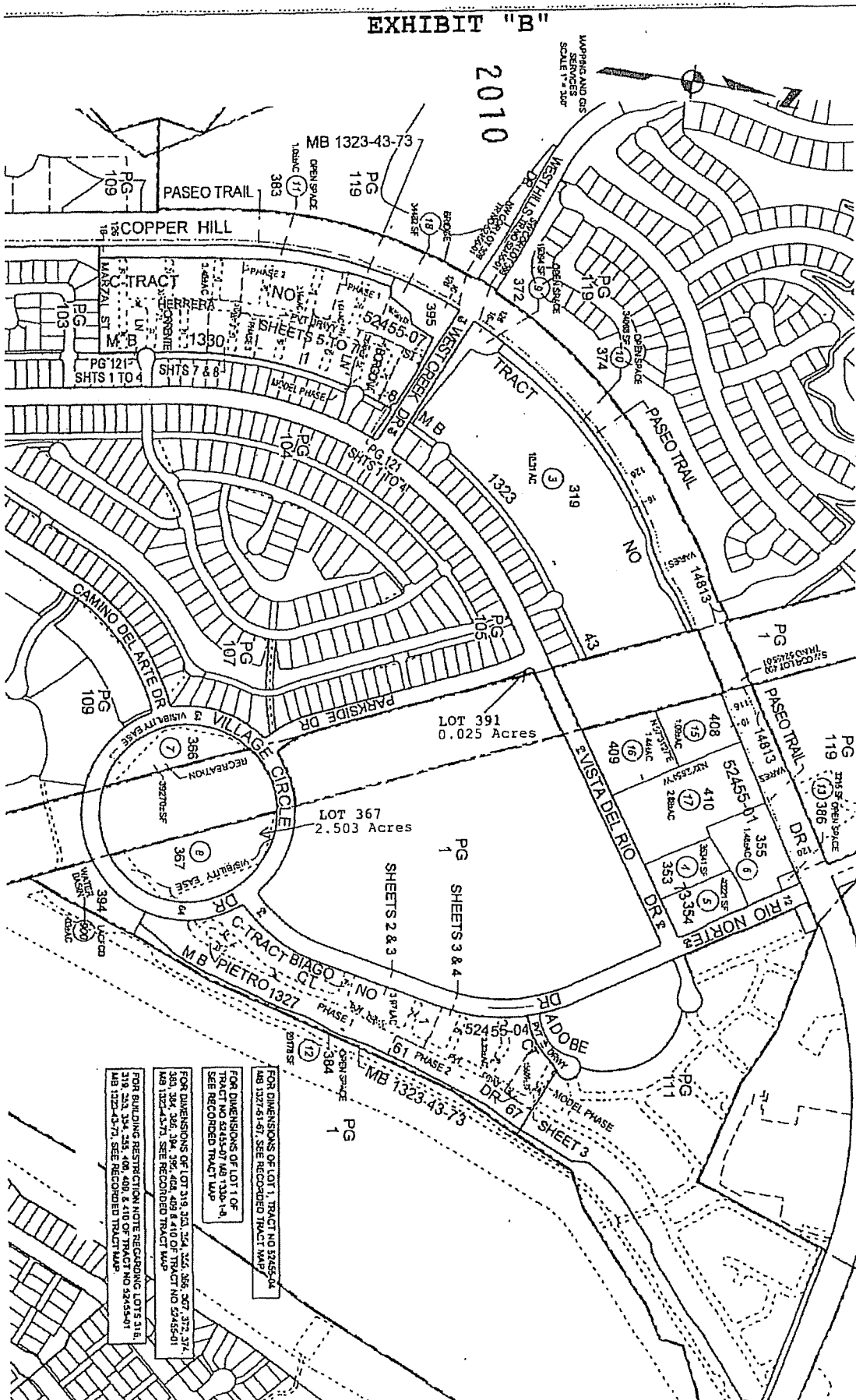

2810	110	P.A.	2810-1, 104	TSA	14813	REVISED	20070227:02065901-B1 20061208:0408001-B1 20070225:0205005001-B1 20070225:0205005001-B1 20061208:0414301-B1	20070227:02065901-B1 20070225:0205005001-B1 20070225:0205005001-B1 20061208:0414301-B1	20070227:02065901-B1 20061208:0408001-B1 20070225:0205005001-B1 20070225:0205005001-B1 20061208:0414301-B1	SEARCH NO	OFFICE OF THE ASSESSOR COUNTY OF LOS ANGELES COPYRIGHT © 2002
------	-----	------	-------------	-----	-------	---------	--	---	--	-----------	---

FOR DIMENSIONS OF LOT 1, TRACT NO 52455-04 MB 1327-61-67, SEE RECORDED TRACT MAP

FOR DIMENSIONS OF LOT 1 OF TRACT NO 52455-07 MB 1320-1-4, SEE RECORDED TRACT MAP

FOR DIMENSIONS OF LOT 318, 323, 324, 325, 326, 327, 372, 374, 383, 384, 385, 394, 395, 404, 409 & 410 OF TRACT NO 52455-01 MB 1322-43-73, SEE RECORDED TRACT MAP

FOR BUILDING RESTRICTION NOTE REGARDING LOTS 318, 319, 323, 324, 325, 408, 409 & 410 OF TRACT NO 52455-01 MB 1322-43-73, SEE RECORDED TRACT MAP



# EXHIBIT A-1

**COPY** of Document Recorded  
on 1/14/10 as No. 0059020  
Has not been compared with original.  
Los Angeles COUNTY RECORDER

**RECORDING REQUESTED BY,  
AND WHEN RECORDED, MAIL TO:**

The Newhall Land and Farming Company  
(A California Limited Partnership)  
23823 Valencia Boulevard  
Valencia, California 91355  
Attention: Fred MacMurdo

SPACE ABOVE LINE FOR RECORDER'S USE ONLY

## ASSIGNMENT AGREEMENT (Surface Rights)

**THIS ASSIGNMENT AGREEMENT** ("Agreement"), is dated as of 1/11, 2010 (the "Effective Date"), and is entered into between The Newhall Land and Farming Company (A California Limited Partnership) ("Newhall"), and the County of Los Angeles ("County"), with reference to the following:

A. Newhall Land conveyed certain real property more particularly described on Attachment A attached hereto and incorporated by this reference ("Property"), to The Metropolitan Water District of Southern California, a public corporation ("MWD"), pursuant to that certain Grant Deed dated as of June 28, 1973, and recorded in the Official Records of Los Angeles County on July 9, 1973, in Book D5937, Page 544 ("Grant Deed").

B. Pursuant to the terms of the Grant Deed, Newhall Land excepted and reserved certain rights with respect to the Property, including, without limitation, the right to use the surface of the Property as more particularly described in the Grant Deed.

C. In accordance with the terms of this Agreement, Newhall Land desires to assign to the County and the County desires to assume from Newhall Land, the non-exclusive right to use the surface of the Property for park purposes in accordance with the terms of the Grant Deed.

**NOW, THEREFORE**, for good and valuable consideration, the receipt and sufficiency of which are hereby acknowledged, Newhall Land and the County hereby agree as follows:

1. Partial Assignment of Surface Rights and Assumption. From and after the Effective Date, Newhall Land hereby assigns and the County hereby assumes, the non-exclusive right to use the surface of the Property as set forth in Section 15 of the Permanent Easement Deed, recorded on June 15, 2007 as Instrument No. 20071449775, for park purposes (collectively, the "County's Surface Rights") over that portion of the Property described and

depicted on Attachment B attached hereto. Except for the foregoing assignment of the County's Surface Rights, Newhall Land hereby reserves all of Newhall Land's rights under the Grant Deed, including, without limitation, the right to grant third-parties the non-exclusive right to use the surface of the Property pursuant to the Grant Deed; provided, however, any such grants shall not unreasonably interfere with the County's use of the County's Surface Rights. County acknowledges that MWD has the paramount right to use the Property for water-related purposes in accordance with the Grant Deed. County will be responsible for notifying the public of any closures of the park on the Property as a result of MWD's exercise of its rights in accordance with the Grant Deed.

2. Indemnity. County shall indemnify, defend and hold harmless Newhall Land, its agents, officers and employees, from and against any and all liability and expense, including defense costs and legal fees, and any rights, claims or actions for damages of any nature whatsoever, including, without limitation, bodily injury, death, personal injury or property damage arising out of the use of the Property pursuant to the County's Surface Rights.

3. Release. Newhall Land and the County hereby acknowledge and agree that from and after the Effective Date, Newhall Land shall be released and discharged of all liabilities and obligations arising out of or related to the County's use of the Property pursuant to the County's Surface Rights.

4. Further Assurances. Newhall Land and the County, for themselves and their legal representatives, successors and assigns, hereby covenant that from time to time after the delivery of this Agreement, at the request of the other party and without further consideration, Newhall Land and/or the County, as applicable, will do, execute, acknowledge and deliver, or will cause to be done, executed, acknowledged and delivered, all further acts, deeds, conveyances, transfers, assignments and assurances as reasonably may be required to carry out the purposes of this Agreement.

5. Successors and Assigns. The provisions of this Agreement shall be binding upon and inure to the benefit of the County, Newhall Land and their respective successors and assigns.

6. Counterparts. This Agreement may be executed in counterparts, each of which shall be deemed a part of an original and all of which together shall constitute one (1) agreement. Signature pages may be detached from the counterparts and attached to a single copy of this Agreement to form one (1) document.

[Signature Page Follows Immediately]

IN WITNESS WHEREOF, Newhall Land and the County have executed this Agreement as of the Effective Date.

**"NEWHALL LAND":**

The Newhall Land And Farming Company  
(A California Limited Partnership), a California  
limited partnership

By: NWHL GP LLC,  
a Delaware limited liability company, its  
general partner

By: LandSource Holding Company, LLC, a Delaware  
limited liability company, its Sole Member

By: Newhall Land Development, LLC, a Delaware limited  
liability company, its Sole Member

By: Newhall Holding Company, LLC, a Delaware limited  
liability company, its Manager

**"COUNTY":**

County of Los Angeles

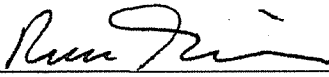
By: 

Name: Russ Guiney

Its: Director of Parks & Recreation

APPROVED AS TO FORM  
County Counsel

By: 

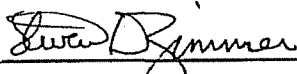
 By: 

Name: STEVEN D. ZIMMER  
Executive Vice President

Its: \_\_\_\_\_

By: 

Name: MARK SUBBOTIN  
Vice President

Its: \_\_\_\_\_

**CALIFORNIA ALL-PURPOSE ACKNOWLEDGEMENT**

STATE OF CALIFORNIA                                     )  
  )     S.S.  
COUNTY OF LOS ANGELES

On 1/11/10 before me B.A. Langeveldt  
Notary Public, personally appeared Steven Zimmer and Mark Subbatin,  
who proved to me on the basis of satisfactory evidence to be the person(s) whose name(s)  
is/are subscribed to the within instrument and acknowledged to me that he/she/they  
executed the same in his/her/their authorized capacity(ies), and that by his/her/their  
signature(s) on the instrument the person(s), or the entity upon behalf of which the  
person(s) acted, executed the instrument.

**I certify under PENALTY OF PERJURY under the laws of the State of California  
that the foregoing paragraph is true and correct.**

WITNESS my hand and official seal.

Signature *B. A. Langeveldt* (Seal)

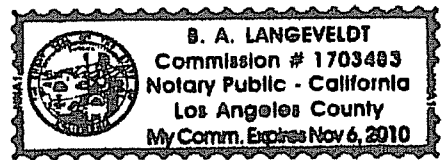

**ATTACHMENT A**

**(Legal Description of the Property)**

[TO BE ATTACHED]

05937 PG 544

125

ELM

Recorded at the Request of  
THE METROPOLITAN WATER DISTRICT  
OF SOUTHERN CALIFORNIA

RECORDED IN OFFICIAL RECORDS  
OF LOS ANGELES COUNTY, CALIF.  
FOR TITLE INSURANCE & TRUST CO.  
JUL 9 1973 AT 8 A.M.  
Registrar-Recorder

When Recorded Return to  
THE METROPOLITAN WATER DISTRICT  
OF SOUTHERN CALIFORNIA  
Post Office Box 54153  
Los Angeles, California 90054

Mail Tax Statements to  
THE METROPOLITAN WATER DISTRICT  
OF SOUTHERN CALIFORNIA  
Post Office Box 54153  
Los Angeles, California 90054

100 5/10/71

DOCUMENTARY TRANSFER TAX \$ None  
(Exempt-Chapter 1108-Statute 1969)

Dec 13-65

This deed is to modify description  
contained in deed recorded 2-6-68  
Book D3905, page 546

GRANT DEED

1600-13-1.1 and 3.1B

For a valuable consideration, THE NEWHALL LAND AND  
FARMING COMPANY, a corporation, hereby grants to

THE METROPOLITAN WATER DISTRICT OF SOUTHERN CALIFORNIA,  
a public corporation,

the following described real property (designated 1600-13-1.1  
and 1600-13-3.1B):

1600-13-1.1

Those certain areas, hereinafter described under  
designation Area A, Area B, and Area C, in Parcels 4, 5, 7, 8,  
and 10, in the Saugus School District, as shown on Licensed  
Surveyor's Map filed in Book 27, pages 32 to 39, of Records of  
Surveys, in the office of the Recorder of the County of Los Angeles,  
and in Rancho San Francisco, as shown on map recorded in Book 1,  
pages 521, et seq., of Patents, in the office of said Recorder,  
in the County of Los Angeles, State of California, said certain  
areas being more particularly described as follows:

RECORDED  
MAY 8 1973

125

DRD5937 PG 545

Grant Deed  
1600-13-1.1 and 3.1B

-2-

AREA A

A strip of land 350 feet wide in said Parcels 4, 5, 7, 8 and 10, the easterly line of said strip of land 350 feet wide being parallel with and 125 feet easterly, measured at right angles from the following described traverse line:

DESCRIPTION APPROVED  
MAY 3 1973

Beginning at a point on the south line of Fractional Section 33, Township 5 North, Range 16 West, San Bernardino Meridian, in the County of Los Angeles, State of California, according to the official plat of said land, said point being distant S 80° 20' 28" E 930.89 feet from the southwest corner of said Fractional Section 33; thence S 36° 46' 28" E 2428.32 feet to a point herein designated Point A; thence continuing S 36° 46' 28" E 420.00 feet; thence S 24° 25' 27" E 630.00 feet to a point herein designated Point B; thence continuing S 24° 25' 27" E 5078.85 feet; thence S 19° 57' 42" E 5612.83 feet to a point herein designated Point C; thence continuing S 19° 57' 42" E 123.70 feet; thence S 17° 48' 24" E 3613.52 feet to a point herein designated Point X; thence continuing S 17° 48' 24" E 182.76 feet to a point herein designated Point Y; thence continuing S 17° 48' 24" E 172.24 feet to a point herein designated Point C-5; thence continuing S 17° 48' 24" E 527.40 feet to a point herein designated Point D; thence continuing S 17° 48' 24" E 1235.00 feet; thence S 61° 33' 17" E 1019.13 feet to the beginning of a tangent curve, concave southwesterly and having a radius of 400 feet; thence southeasterly along said last mentioned curve through a central angle of 23° 34' 12", an arc distance of 164.55 feet; thence S 37° 59' 05" E 1054.85 feet to a point on the easterly prolongation of the northerly line of Block 9, of Tract No. 1801, as shown on map recorded in Book 21, page 158, of Maps in the office of said Recorder, said last mentioned point being distant N 81° 19' 22" E 27.42 feet from the northeast corner of Block 9 of said Tract No. 1801.

The side lines of said above-described 350-foot wide strip of land shall be prolonged or shortened so as to terminate northwesterly in a line drawn at right angles to said above-described traverse line from said "Point B" and so as to terminate southeasterly in a line drawn at right angles to said above traverse line at said "Point D".

EXCEPTING therefrom the westerly 100 feet of that portion of said 350-foot wide strip of land lying northerly of a line drawn at right angles to said above-described traverse line from said "Point C".

125

BX 05937 PG 546

-3-

ALSO EXCEPTING therefrom that portion of said 350-foot wide strip of land lying between a line having a bearing of N 88° 13' 59" W and which passes through said Point X and a line having a bearing of N 88° 13' 59" W and which passes through said Point Y.

AREA B

A parcel of land in said Parcel 7 in the Saugus School District being more particularly described as follows:

Beginning at said "Point A" in the traverse line of Area A hereof; thence N 93° 13' 32" E 300.00 feet; thence S 36° 46' 28" E 452.47 feet; thence S 24° 25' 27" E 662.45 feet to a line drawn at right angles to said traverse line from said "Point B"; thence S 65° 34' 33" W along said right angle line a distance of 551.01 feet; thence N 36° 46' 28" W 981.73 feet to a line drawn at right angles to said traverse line from said "Point A"; thence N 53° 13' 32" E along said line at right angles, a distance of 379.95 feet to the point of beginning.

AREA C

A parcel of land in said Parcels 4 and 10, and in said Rancho San Francisco more particularly described as follows:

Beginning at said "Point D" in the traverse line of Area A hereof; thence S 72° 11' 36" W at right angles to said traverse line, 125 feet to a line that is parallel with and distant 125 feet westerly, measured at right angles, from said traverse line; thence S 17° 48' 24" E along said last mentioned parallel line and its southerly prolongation to the intersection of a line that is parallel with and distant 200 feet southwesterly, measured at right angles, from that certain course in said traverse line having a bearing of S 61° 33' 17" E; thence S 61° 33' 17" E along said last mentioned parallel line to a line parallel with and distant westerly 150.00 feet, measured at right angles or radially from the westerly line of Bouquet Canyon Road as described in the deed to the State of California recorded in Book 12616, page 117, of Official Records, in the office of the County Recorder of said county; thence southerly along said last mentioned parallel line to a line parallel with and distant northerly 100.00 feet, measured at right angles from the northerly line of the land described in the deed to Saugus School District recorded on September 10, 1943, as Instrument No. 264, in Book 20238, page 347 of said Official Records; thence easterly along said last mentioned parallel line to the most easterly line of the land described in

DESCRIPTION APPROVED  
MAY 3 1973

125



BK 05937 PG 547

Grant Deed  
1600-13-1.1 and 3.1B

-4-

DESCRIPTION APPROVED  
MAY 3 1973

the deed to Newhall Land and Farming Company, recorded in Book 29106, page 258, of Official Records in the office of said Recorder; thence northerly along said most easterly line to the intersection of a line that is parallel with and distant 250 feet northeasterly, measured at right angles, from said traverse line having a bearing of S 61° 33' 17" E; thence N 61° 33' 17" W along said parallel line and its northwesterly prolongation to the intersection of a line that is parallel with and distant 125 feet easterly, measured at right angles, from said traverse line having a bearing of S 17° 48' 24" E; thence N 17° 48' 24" W along said parallel line to a line drawn at right angles to said traverse line from said "Point D"; thence S 72° 11' 36" W along said last mentioned line to the point of beginning.

EXCEPTING therefrom all water, minerals, oil, gas, or other hydrocarbon substances in and under said land without the right of surface entry for the development thereof, provided, further, that there shall be no drilling for extraction of same beneath the surface of said land to a depth of 500 feet.

1600-13-3.1B

A parcel of land in said Parcel 4 of the Saugus School District, said parcel of land being more particularly described as follows:

Commencing at said Point C-5 of the traverse line of Area A described above; thence S 72° 11' 36" W at right angles to said traverse line, 225.00 feet to a point on a line which is parallel with and distant 225 feet southwesterly, measured at right angles, from said traverse line, said point being the TRUE POINT OF BEGINNING; thence N 17° 48' 24" W along said parallel line a distance of 252.24 feet to a point on a line having a bearing of N 88° 13' 59" W and which passes through said Point Y; thence N 88° 13' 59" W along said line 143.28 feet to a line which is parallel with and distant 360 feet southwesterly, measured at right angles, from said traverse line; thence S 17° 48' 24" E along said last mentioned parallel line, 300.24 feet to said line which is at right angles to the above traverse line and passes through said Point C-5; thence N 72° 11' 36" E 135.00 feet, more or less, to said True Point of Beginning.

EXCEPTING from said above described real property designated 1600-13-1.1 and 1600-13-3.1B that portion thereof included within the real property conveyed to The Metropolitan Water District of Southern California by deed recorded in Book D3905, page 546, of Official Records in the office of said Recorder.

125

Grant Deed  
1600-13-1.1 and 3.1B

-5-

OR 05937 PG 548

EXCEPTING therefrom all water, minerals, oil, gas or other hydrocarbon substances in and under said land without the right of surface entry for the development thereof; provided, further that there shall be no drilling for extraction of same beneath the surface of said land to a depth of 500 feet.

Reserving to Grantor after completion of Grantee's Foothill Feeder within the above-described property or January 1, 1972, whichever occurs first, the right to use such property for agricultural purposes, landscaping (except for trees), transverse roads and streets, public utilities, parking purposes and, subject to prior approval by Grantee, for any other use which shall not in Grantee's opinion, reasonably exercised, interfere with Grantee's use of such property for its Foothill Feeder; provided, however, that (1) Grantor shall construct no permanent structures on such property other than pavement, drains, television cables, water lines, gas lines, oil lines, and other utilities; and (2) Grantee shall have the right to use existing roads over Grantor's land, as approximately shown on the drawing attached hereto, for ingress to and egress from the above-described property. Should such roads cease to exist, Grantor shall provide adequate substitute roads, and (3) Grantee shall have the right to use such property for the purpose of maintaining, operating, enlarging, reconstructing, or adding to its pipelines thereunder, whenever such use may become necessary in the sole discretion of Grantee, to the same extent as if the rights hereinabove mentioned had not been reserved, and Grantee shall not be liable for any damages resulting from such work to improvements put on the above-described property by Grantor, except that (a) Grantee shall replace any paving or drains which are destroyed during construction of Grantee's second pipeline of its Foothill Feeder within such property. Also, during such construction, any television cables, water lines, gas lines, oil lines, or other utilities, as mentioned above, shall be maintained in service, and (b) Grantee shall join in the dedication of any road or street hereinabove authorized to be constructed. Said reservation shall apply to Parcel 1600-13-1.1 and to Parcel 1600-13-3.1B.

DESCRIPTION ATTACHED  
MAY 2 1973  
125

Dated: June 28, 1973

THE NEWHALL LAND AND FARMING COMPANY

By Peter C. Kremer  
PETER C. KREMER SENIOR VICE PRESIDENT

By Edward A. Toney  
EDWARD A. TONEY ASSISTANT SECRETARY

125

bx 05937 pg 549

STATE OF CALIFORNIA )  
 ) SS.  
COUNTY OF LOS ANGELES )

On June 28, 1973, before me, the undersigned,  
a Notary Public in and for said State, personally appeared

PETER C. KREMER, known to me to be the

Senior Vice President, and EDWARD A. TONEY,

known to me to be Assistant Secretary  
of the corporation that executed the within instrument on  
behalf of the corporation therein named, and acknowledged  
to me that such corporation executed the within instrument  
puraunt to its by-laws or a resolution of its Board of  
Directors.

WITNESS my hand and official seal.

Signature Geraldine A. Stinch

Notary Public in and for  
said State

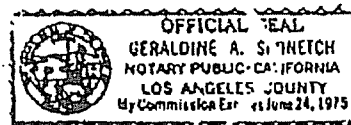

1010 Honey Bayo Rd., Valencia, Calif. 91355

125

BR 05937 PG 550

12-64  
Rev. 10/20/69  
RW-1

Certificate of Acceptance

This is to certify that the interest in real property conveyed by this deed dated June 28, 1973 from The Newhall Land and Farming Co.

to The Metropolitan Water District of Southern California, a public corporation, is hereby accepted by the undersigned officer on behalf of the Board of Directors of said District pursuant to authority conferred by Resolution 6615 of said Board adopted on November 17, 1964, and the grantee consents to recordation thereof by its duly authorized officer.

Dated JUN 29 1973.

THE METROPOLITAN WATER DISTRICT  
OF SOUTHERN CALIFORNIA

By Maynard M. Anderson  
General Manager  
Maynard M. Anderson  
Assistant General Manager

MLH

- Transaction authorized by Resolution 6614
- Transaction authorized by Resolution 6614 (Land Committee)
- Transaction authorized by Board of Directors on

125

**ATTACHMENT B**

**(Legal Description of County's Surface Rights)**

[TO BE ATTACHED]

1 ATTACHMENT B

2 LEGAL DESCRIPTION

3 Those certain parcels of land hereinafter designated as Parcel A, Parcel B, Parcel C and  
4 Parcel D, being portions of the Rancho San Francisco, in the Unincorporated Territory of  
5 the County of Los Angeles, State of California, recorded in Book 1, Pages 521 and 522,  
6 of Patents, records of said County lying within that certain real property conveyed to the  
7 Metropolitan Water District of Southern California as Area "A", by deeds recorded on  
8 October 3, 1967 in Book D3786 Page 579, on February 6, 1968 in Book D3905 Page  
9 546, and on July 9, 1973 in Book D5937 Page 544, all of Official Records in the office of  
10 the County Recorder of said County, being a 250 foot wide strip of land shown as Parcel  
11 1 on the map of Record of Survey filed in book 86 pages 43 through 48 inclusive of  
12 Record of Surveys, records of said County described as follows:

13  
14 PARCEL A

15  
16 Beginning at a point in the northeasterly line of said 250 foot strip shown as having a  
17 bearing and distance of "South 24° 25' 27" East 5083.72 feet" distant thereon South 24°  
18 25' 27" East a distance of 1237.04 feet from the northwesterly terminus of said  
19 northeasterly line, said point also being the northeasterly corner of Parcel "A" per  
20 Instrument 02-2229619, recorded on September 23, 2002 in Official Records of said  
21 County; thence northwesterly along said northeasterly line, North 24° 25' 27" West, a  
22 distance of 520.19 feet to the southeasterly line of a permanent street easement per  
23 Instrument 02-0049215, recorded January 08, 2002 in Official Records of said County;  
24 thence southwesterly leaving said northeasterly line along the southeasterly line of said  
25 Instrument 02-0049215, South 57° 31' 38" West, a distance of 252.49 feet to the  
26 southwesterly line of said 250 foot strip; thence along said southwesterly line South 24°  
27 25' 27" East, a distance of 530.21 feet, to the northwest corner of said Parcel "A" of  
28 instrument 02-2229619; thence northeasterly along the northwesterly line of said

ATTACHMENT B

Foothill Feeder  
MWD Parcel No. 1600-13-1 (Por.)  
Permanent Easement RL No. 2061  
MWD to The County of Los Angeles

1 last mentioned Parcel "A" North 55° 17' 24" East, a distance of 254.08 feet to the point of  
2 beginning.

3  
4 Containing 3.014 acres of land, more or less.  
5

6  
7 **PARCEL B**  
8

9 Beginning at a point in the northeasterly line of said 250 foot wide strip shown as having  
10 a bearing and distance of "South 24° 25' 27" East 5083.72 feet" distant thereon South  
11 24° 25' 27" East 2305.06 feet from the northwesterly terminus of said northeasterly line,  
12 said point also being the northeasterly corner of Parcel "B" per Instrument 02-2229619,  
13 recorded on September 23, 2002 in Official Records of said County; thence northwesterly  
14 along said northeasterly line, North 24° 25' 27" West, a distance of 1,002.97 feet to the  
15 southeasterly line of said Parcel "A" per Instrument 02-2229619, thence southwesterly  
16 leaving said northeasterly line along the southeasterly line of said last mentioned Parcel  
17 "A" South 55° 17' 24" West, a distance of 254.08 feet to the southwesterly line of said  
18 250 foot strip; thence southeasterly along said southwesterly line, South 24° 25' 27" East,  
19 a distance of 804.47 feet to the beginning of a tangent curve concave to the northeast  
20 having a radius of 368.00 feet, said tangent curve also being the easterly line of Parcel  
21 "C" per Instrument 02-2229619, recorded on September 23, 2002 in Official Records of  
22 said County; thence southeasterly along said curve and said Parcel "C" through a central  
23 angle of 24° 48' 21", an arc distance of 159.32 feet; thence South 49° 13' 48" East, a  
24 distance of 3.08 feet to the beginning of a tangent curve concave to the north having a  
25 radius of 13.00 feet; thence easterly along said curve through a central angle of 83° 27'  
26 30", an arc distance of 18.94 feet to the beginning of a tangent reverse curve, concave  
27 southeasterly, having a radius of 382.00 feet, a radial line to said curve bears North 42°  
28 41' 18" West, said tangent reverse curve, also being the Northerly line of Parcel "B" per  
29 Instrument 02-2229619, thence northeasterly along said curve and said last mentioned

ATTACHMENT B

Foothill Feeder  
MWD Parcel No. 1600-13-1 (Por.)  
Permanent Easement RL No. 2061  
MWD to The County of Los Angeles

1 Parcel "B" through a central angle of 30° 13' 26", an arc distance of 201.51 feet to the  
2 point of beginning.

3  
4 Containing 5.576 acres of land, more or less.  
5

6  
7 **PARCEL C**  
8

9 Beginning at a point in the northeasterly line of said 250 foot wide strip shown as having  
10 a bearing and distance of "South 24° 25' 27" East 5083.72 feet" distant thereon South  
11 24° 25' 27" East 2986.76 feet from the northwesterly terminus of said northeasterly line,  
12 said point being the northeast corner of Parcel "D" per Instrument 02-2229619, recorded  
13 on September 23, 2002 in Official Records of said County, thence northwesterly along  
14 said northeasterly line, North 24° 25' 27" West, a distance of 615.98 feet to the  
15 southeasterly line of said Parcel "B" per Instrument 02-2229619, said point being the  
16 beginning of a non tangent curve concave southeasterly, having a radius of 318.00 feet, a  
17 radial line to said curve bears North 10° 00' 35" West; thence leaving said northeasterly  
18 line southwesterly along said curve and said last mentioned Parcel " B", through a central  
19 angle of 46° 54' 35", an arc distance of 260.36 feet to the southwesterly line of said 250  
20 foot wide strip; thence along said southwesterly line South 24° 25' 27" East, a distance of  
21 497.55 feet to the beginning of a non-tangent curve, concave northerly, having a radius of  
22 286.00 feet and to which beginning a radial line bears South 12° 16' 04" West; thence  
23 easterly 39.89 feet along said curve, through a central angle of 07° 59' 28" to the  
24 beginning of a reverse curve, concave to the south and having a radius of 25.00 feet;  
25 thence easterly 11.89 feet along said curve through a central angle of 27° 15' 07" to the  
26 beginning of a non-tangent curve, concave to the west, having a radius of 85.00 feet and  
27 to which beginning a radial line bears South 88° 25' 34" East; thence southerly 5.88 feet  
28 along said curve through a central angle of 03° 57' 46" to the beginning of a non-tangent  
29 curve, concave to the southwest, having a radius of 20.00 feet and to which beginning a



ATTACHMENT B

Foothill Feeder  
MWD Parcel No. 1600-13-1 (Por.)  
Permanent Easement RL No. 2061  
MWD to The County of Los Angeles

1 radial line bears North 39° 27' 07" East; thence southeasterly 3.09 feet along said curve  
2 through a central angle of 08° 51' 28" to the beginning of a compound curve, concave to  
3 the west and having a radius of 31.00 feet; thence southerly 23.13 feet along said curve  
4 through a central angle of 42° 44' 28" to the non-tangent curved northwesterly line of  
5 said Parcel "D", said curve being concave to the north, having a radius of 318.00 feet and  
6 to which intersection a radial line bears South 00° 03' 58" West; thence easterly 215.93  
7 feet along said curve, through a central angle of 38° 54' 17" to the point of beginning.

8

9 Containing 3.477 acres of land, more or less.

10

11

12 **PARCEL D**

13

14 Beginning at a point in the northeasterly line of said 250 foot wide strip shown as having  
15 a bearing and distance of "South 24° 25' 27" East 5083.72 feet" distant thereon South  
16 24° 25' 27" East 3291.80 feet from the northwesterly terminus of said northeasterly line;  
17 thence northwesterly along said northeasterly line, North 24° 25' 27" West, a distance of  
18 239.32 feet to the southeasterly line of said Parcel "D" per Instrument 02-2229619, said  
19 point also being the beginning of a non tangent curve concave northerly, having a radius  
20 of 382.00 feet, a radial line to said curve bears South 36° 23' 02" East; thence leaving  
21 said northeasterly line westerly along said curve and said last mentioned Parcel "D",  
22 through a central angle of 38° 31' 32", an arc distance of 256.86 feet to the southwesterly  
23 line of said 250 foot strip; thence along said southwesterly line South 24° 25' 27" East, a  
24 distance of 645.10 feet; thence leaving said southwesterly line, North 02° 53' 02" East, a  
25 distance of 287.31 feet; thence North 20° 30' 47" East, a distance of 167.33 feet to the  
26 point of beginning.

27

28 Containing 2.288 acres of land, more or less.

29

ATTACHMENT B

Foothill Feeder  
MWD Parcel No. 1600-13-1 (Por.)  
Permanent Easement RL No. 2061  
MWD to The County of Los Angeles

1 Parcels A, B, C and D contain a total of 14.355 acres, more or less.

2

3 The above described Parcels are shown on the attached sketch and made a part hereof.

4

5

6 Prepared under the direction of:

7

8

9

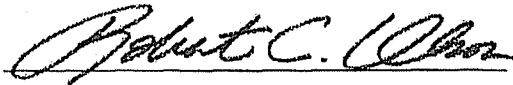

8.16.2006

10 Robert C. Olson, PLS 5490

Date

11

12

13

14

15

16

17

18

19

20

21

22

23

24

25

26

27

28

29

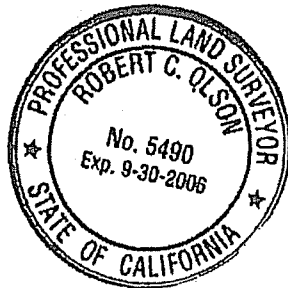

SCALE: 1" = 100'

# ATTACHMENT 'B' PARCEL C

SHEET 4 OF 5 SHEETS

THIS EXHIBIT IS TO BE ATTACHED TO THE LEGAL DESCRIPTION  
PORTION OF RANCHO SAN FRANCISCO, RECORDED IN BOOK 1, PAGES 521 AND 522  
OF PATENTS, IN THE UNINCORPORATED TERRITORY OF THE COUNTY  
OF LOS ANGELES, IN THE STATE OF CALIFORNIA



CURVE TABLE			
CURVE	RADIUS	DELTA	LENGTH
C1	318.00	46°54'35"	260.36
C2	318.00	38°54'17"	215.93
C3	286.00	7°59'28"	39.89
C4	25.00	27°15'07"	11.89
C5	85.00	3°57'46"	5.88
C6	31.00	42°44'28"	23.13
C7	20.00	8°51'27"	3.09

PARCEL C  
INST. NO. 02-2229619  
REC'D 9/23/02 O.R.

PARCEL B  
INST. NO. 02-2229619  
REC'D 9/23/02 O.R.

PARCEL "C"

(1600-13-1 & 1600-13-1.1)  
D5937/544 O.R. REC. 07-09-73  
D3905/546 O.R. REC. 02-06-68  
D3786/579 O.R. REC. 10-03-67

PARCEL D  
INST. NO. 02-2229619  
REC'D 9/23/02 O.R.

**LEGEND:**

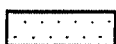

PERMANENT EASEMENT  
1600-13-1(POR.)  
PARCEL C = 3.477 AC

NOT A PART

PREPARED UNDER MY SUPERVISION

*Robert C. Olson*  
ROBERT C. OLSON  
PLS 5490

DATE

08.16.2006

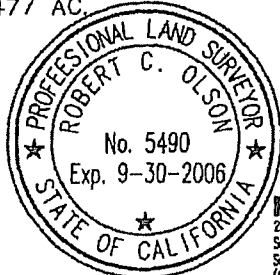

**PSOMAS**  
28470 Avenue Stanford  
Suite 300  
Santa Clarita, CA 91355  
(818)219-6000 (661)775-2710(FAX)

THE METROPOLITAN WATER DISTRICT  
OF SOUTHERN CALIFORNIA

FOOTHILL FEEDER  
PERMANENT EASEMENT  
RL No. 2061  
MWD TO

THE COUNTY OF LOS ANGELES  
1600-13-1(POR.)

Plotted: 08/16/06 16:53:50 v:\NorthRiv\PRODDATA\52455\AREA\_C\Exhib\PL\WC209\wc209-04.dwg rolsen

SCALE: 1" = 100'

SHEET 5 OF 5 SHEETS

# ATTACHMENT 'B' PARCEL D

THIS EXHIBIT IS TO BE ATTACHED TO THE LEGAL DESCRIPTION  
PORTION OF RANCHO SAN FRANCISCO, RECORDED IN BOOK 1, PAGES 521 AND 522  
OF PATENTS, IN THE UNINCORPORATED TERRITORY OF THE COUNTY  
OF LOS ANGELES, IN THE STATE OF CALIFORNIA

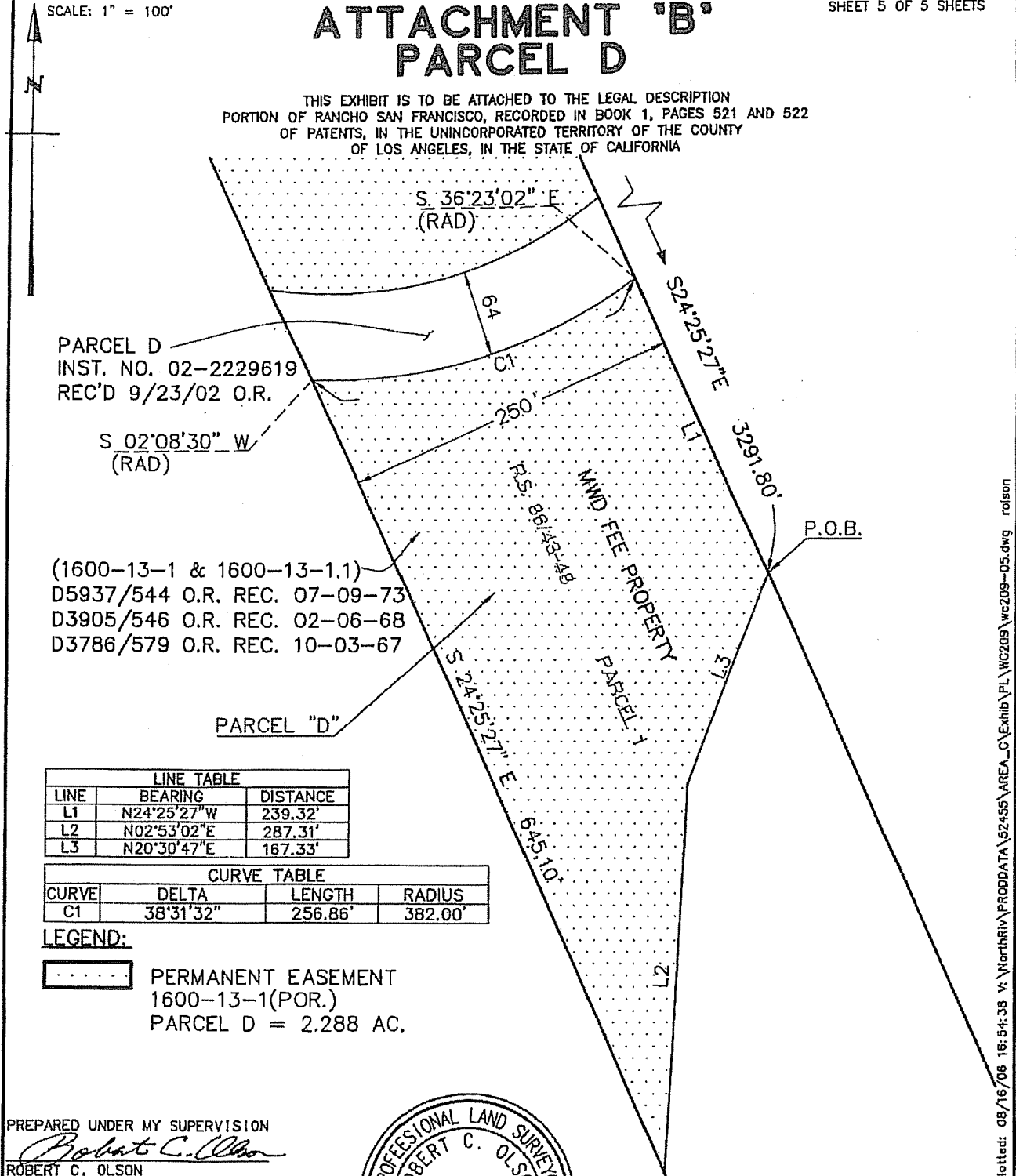

PARCEL D  
INST. NO. 02-2229619  
REC'D 9/23/02 O.R.

S 02°08'30" W  
(RAD)

(1600-13-1 & 1600-13-1.1)  
D5937/544 O.R. REC. 07-09-73  
D3905/546 O.R. REC. 02-06-68  
D3786/579 O.R. REC. 10-03-67

PARCEL "D"

LINE TABLE		
LINE	BEARING	DISTANCE
L1	N24°25'27"W	239.32'
L2	N02°53'02"E	287.31'
L3	N20°30'47"E	167.33'

CURVE TABLE			
CURVE	DELTA	LENGTH	RADIUS
C1	38°31'32"	256.86'	382.00'

**LEGEND:**

PERMANENT EASEMENT  
1600-13-1(POR.)  
PARCEL D = 2.288 AC.

PREPARED UNDER MY SUPERVISION

*Robert C. Olson*  
ROBERT C. OLSON  
PLS 5490

DATE 08.16.2006

**PSOMAS**  
28470 Avenue Stanford  
Suite 300  
Santa Clarita, CA 91355  
(661)219-6000 (661)775-2718(FAX)



THE METROPOLITAN WATER DISTRICT  
OF SOUTHERN CALIFORNIA  
FOOTHILL FEEDER  
PERMANENT EASEMENT  
RL No. 2061  
MWD TO  
THE COUNTY OF LOS ANGELES  
1600-13-1(POR.)

Plotted: 08/16/06 16:54:38 V:\Northriv\PRODDATA\52455\AREA\_C\Exhib\PL\WC209\wc209-05.dwg rolson

# EXHIBIT B

This page is part of your document - DO NOT DISCARD



## 20110481496



Pages:  
0027

Recorded/Filed in Official Records  
Recorder's Office, Los Angeles County,  
California

03/31/11 AT 11:45AM

FEES :	0.00
TAXES :	0.00
OTHER :	0.00
PAID :	0.00



LEADSHEET



201103310030054

00003970851



003240832

SEQ:  
16

DAR - Counter (Hard Copy)



**THIS FORM IS NOT TO BE DUPLICATED**

**ORIGINAL**

WHEN RECORDED, MAIL TO:

County of Los Angeles  
Department of Public Works  
P.O. Box 1460  
Alhambra, CA 91802-1460  
Attention: Land Development Division  
Road and Grading Section



2

(Space Above This Line for Recorder's Use)

THIS DOCUMENT IS EXEMPT FROM DOCUMENTARY TRANSFER TAX  
PURSUANT TO SECTION 11922 OF THE REVENUE & TAXATION CODE

THIS DOCUMENT IS EXEMPT FROM RECORDING FEES PURSUANT TO  
SECTION 27383 OF THE GOVERNMENT CODE

Assessor's Identification Numbers:  
2810-002-088, 2802-109-014 & 015,  
2810-110-012 & 2810-111-004

## GRANT OF EASEMENT

WHEREAS, THE NEWHALL LAND AND FARMING COMPANY (A CALIFORNIA LIMITED PARTNERSHIP), a limited partnership, (hereinafter referred to as GRANTOR), is the owner of open space areas and lots shown on Parcel Map No. 25802, filed in Book 338, page 23, of Parcel Maps, and shown on the map of Tract No. 52455-01, filed in Book 1323, page 43, of Maps (TRACTS); and

WHEREAS, GRANTOR has constructed a paved trail (hereinafter TRAIL IMPROVEMENTS) as depicted in Exhibit B, attached hereto and by this reference made a part hereof, on a portion of TRACTS, as legally described in Exhibit A which is attached hereto and by this reference made a part hereof; and

2  
1

WHEREAS, it is in the public interest for the TRAIL IMPROVEMENTS to be dedicated to the County of Los Angeles for public recreational uses.

NOW, THEREFORE, GRANTOR hereby grants to the County of Los Angeles, a body corporate and politic (hereinafter referred to as COUNTY), an easement (hereinafter referred to as EASEMENT) for access road and public recreational trail purposes, including without limitation, the right to install, maintain, repair and/or replace a Class I Bike Trail in, on, over, under and across the property described in Exhibit A (hereinafter referred to as EASEMENT AREA), together with the TRAIL IMPROVEMENTS located thereon.

The GRANTOR and the COUNTY, hereby agree as follows:

1. That the COUNTY shall be obligated to maintain the TRAIL IMPROVEMENTS and any other improvements constructed or installed by COUNTY pursuant to this EASEMENT.
2. GRANTOR agrees that it will set forth the following condition in any grant of easements in, on, over, under, or across the EASEMENT AREA:

"Grantee agrees that it will not perform nor arrange for the performance of any work in, on, over, under, or, across the land herein described until the plans and specifications for such work shall have first been submitted to and approved in writing by the Director of Public Works, of the County of Los Angeles."

3. GRANTOR hereby reserves for itself, and its successors and assigns, the right of access, ingress and egress as may be reasonably necessary to properly maintain the areas adjacent to the EASEMENT AREA, provided that GRANTOR shall provide written notice to COUNTY prior to entering the EASEMENT AREA and shall repair any damage to the TRAIL IMPROVEMENTS or other improvements within the EASEMENT AREA caused by GRANTOR'S use of the EASEMENT AREA, to the satisfaction of COUNTY, which shall not be unreasonably withheld or



delayed. Furthermore GRANTOR shall be allowed to assign this right to other entities ("FUTURE ASSIGNEE") provided that any such assignment expressly requires the FUTURE ASSIGNEE to notify COUNTY in writing prior to entering the EASEMENT AREA and to restore any damage to the TRAIL IMPROVEMENTS or other improvements within the EASEMENT AREA caused by FUTURE ASSIGNEE'S use of the EASEMENT AREA, to the satisfaction of COUNTY, which shall not be unreasonably withheld or delayed. The parties hereto agree that neither GRANTOR nor a FUTURE ASSIGNEE shall be required to provide written notice in the event an emergency necessitates access to any areas adjacent to the easement.

4. The terms and conditions contained in this Grant of Easement document shall be binding upon the GRANTOR, the COUNTY, their successors, and/or assigns.
5. This agreement may be executed in counterparts and shall constitute one agreement which shall be binding, notwithstanding that all the parties' signatures may not appear on the same page.
6. In the event of any controversy, claim or dispute arising out of or relating to this Grant of Easement or the breach, enforcement, interpretation or validity thereof, the issue shall be submitted to mediation by a mutually agreed mediator, with the costs to be shared equally between the parties to the mediation. The parties shall participate in mediation or other acceptable means of alternative dispute resolution prior to seeking any other recourse.
7. To the fullest extent allowed or permitted under or not prohibited by any provision of applicable law, COUNTY shall indemnify, defend and hold harmless GRANTOR and each of GRANTOR'S owners, partners, officers, employees, and agents ("Covered Persons") from and against any losses, expenses (including reasonable costs, expenses and attorneys' and paralegals' fees), judgments, penalties (including excise and similar taxes and punitive damages), fines, settlements and damages incurred by GRANTOR or such Covered Persons arising out of any threatened, pending or completed claim, action, suit or proceeding (a "Proceeding"), whether civil, criminal, administrative or arbitrative, including any appeal of any such Proceeding, or any inquiry or investigation that could lead to such a Proceeding, based upon acts (including negligent acts, whether or not under a theory of strict liability) performed or omitted to be performed by COUNTY or COUNTY'S contractors, employees, and agents incident or related to COUNTY'S and its contractors, employees, and agents use of the EASEMENT created herewith, including without limitation any public use of the EASEMENT permitted by COUNTY. Excepting any breach of GRANTOR'S repair obligations described in paragraph 3, above, or any negligence by GRANTOR, GRANTOR shall have no liability whatsoever for any damages to person or property arising from use of the EASEMENT by members of the public, nor shall GRANTOR be responsible for the installation or maintenance of any signage in the EASEMENT AREA, intended to be seen by the general public.
8. To the fullest extent allowed or permitted under or not prohibited by any provision of applicable law, GRANTOR, including any FUTURE ASSIGNEE, shall indemnify, defend and hold harmless COUNTY and each of COUNTY'S officers, employees, and agents ("Covered Persons") from and against any losses, expenses (including reasonable costs, expenses and attorneys' and paralegals' fees), judgments, penalties (including punitive damages), fines, settlements and damages incurred by COUNTY or such Covered Persons arising out of any threatened, pending or completed claim, action, suit or proceeding (a "Proceeding"), whether civil, criminal, administrative or arbitrative, including any appeal of any such Proceeding, based upon acts (including negligent acts, whether or not under a theory of strict liability) performed or omitted to be performed by GRANTOR or any FUTURE ASSIGNEE or their respective contractors, employees or agents incident or related to the use of the EASEMENT AREA.



*[Signature page follows]*



Dated 03/01/2011

5

THE NEWHALL LAND AND FARMING COMPANY,  
(A CALIFORNIA LIMITED PARTNERSHIP), a limited partnership

By: NWHL GP LLC,  
a Delaware limited liability company, its General Partner

By: LandSource Holding Company, LLC,  
a Delaware limited liability company, its Sole Member

By: Newhall Land Development, LLC,  
a Delaware limited liability company, its Sole Member

By: Newhall Holding Company, LLC,  
a Delaware limited liability company, its Manager

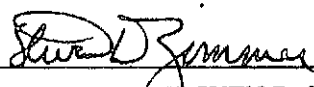
By:   
Name: STEVEN D. ZIMMER  
Executive Vice President

Title: \_\_\_\_\_

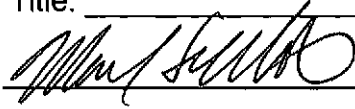
By:   
Name: MARK SUBBOTIN  
Vice President

Title: \_\_\_\_\_

Pursuant to the authority granted in an order adopted by the Board of Supervisors of the County of Los Angeles on September 24, 1995, the Director of the Department of Public Works has executed this Grant of Easement document on the 30th day of March, 2002.

APPROVED AS TO FORM  
ANDREA SHERIDAN ORDIN  
County Counsel

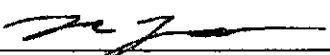
By:   
Deputy

COUNTY OF LOS ANGELES,  
a body corporate and politic  
GAIL FARBER  
Director of Public Works

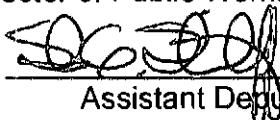
By:   
Assistant Deputy Director

West Creek Bike Trail Easement  
Project No. LD52455A

60

# CALIFORNIA ALL-PURPOSE CERTIFICATE OF ACKNOWLEDGMENT

State of California

County of LOS ANGELES

On 03/01/2011 before me, CARMELITA VIDAD, NOTARY PUBLIC  
(Here insert name and title of the officer)

personally appeared STEVEN D. ZIMMER AND MARK SUBBOTIN

who proved to me on the basis of satisfactory evidence to be the person(s) whose name(s) ~~is~~ are subscribed to the within instrument and acknowledged to me that ~~he/she~~ they executed the same in ~~his/her~~ their authorized capacity(ies), and that by ~~his/her~~ their signature(s) on the instrument the person(s), or the entity upon behalf of which the person(s) acted, executed the instrument.

I certify under PENALTY OF PERJURY under the laws of the State of California that the foregoing paragraph is true and correct.

WITNESS my hand and official seal.

*Carmelita Vidad*

Signature of Notary Public

(Notary Seal)



## ADDITIONAL OPTIONAL INFORMATION

### DESCRIPTION OF THE ATTACHED DOCUMENT

\_\_\_\_\_  
(Title or description of attached document)

\_\_\_\_\_  
(Title or description of attached document continued)

Number of Pages \_\_\_\_\_ Document Date \_\_\_\_\_

\_\_\_\_\_  
(Additional information)

### CAPACITY CLAIMED BY THE SIGNER

- Individual (s)
- Corporate Officer

\_\_\_\_\_  
(Title)

- Partner(s)
- Attorney-in-Fact
- Trustee(s)
- Other \_\_\_\_\_

### INSTRUCTIONS FOR COMPLETING THIS FORM

*Any acknowledgment completed in California must contain verbiage exactly as appears above in the notary section or a separate acknowledgment form must be properly completed and attached to that document. The only exception is if a document is to be recorded outside of California. In such instances, any alternative acknowledgment verbiage as may be printed on such a document so long as the verbiage does not require the notary to do something that is illegal for a notary in California (i.e. certifying the authorized capacity of the signer). Please check the document carefully for proper notarial wording and attach this form if required.*

- State and County information must be the State and County where the document signer(s) personally appeared before the notary public for acknowledgment.
- Date of notarization must be the date that the signer(s) personally appeared which must also be the same date the acknowledgment is completed.
- The notary public must print his or her name as it appears within his or her commission followed by a comma and then your title (notary public).
- Print the name(s) of document signer(s) who personally appear at the time of notarization.
- Indicate the correct singular or plural forms by crossing off incorrect forms (i.e. ~~he/she/they~~ is /are ) or circling the correct forms. Failure to correctly indicate this information may lead to rejection of document recording.
- The notary seal impression must be clear and photographically reproducible. Impression must not cover text or lines. If seal impression smudges, re-seal if a sufficient area permits, otherwise complete a different acknowledgment form.
- Signature of the notary public must match the signature on file with the office of the county clerk.
  - ❖ Additional information is not required but could help to ensure this acknowledgment is not misused or attached to a different document.
  - ❖ Indicate title or type of attached document, number of pages and date.
  - ❖ Indicate the capacity claimed by the signer. If the claimed capacity is a corporate officer, indicate the title (i.e. CEO, CFO, Secretary).
- Securely attach this document to the signed document

7

### ACKNOWLEDGMENT FORM

STATE OF CALIFORNIA )  
 )  
COUNTY OF \_\_\_\_\_ ) ss.

On \_\_\_\_\_, before me, \_\_\_\_\_, Notary Public,  
(insert name of the officer) (insert title of the officer)

personally appeared \_\_\_\_\_

(insert name(s) and title(s))

who proved to me on the basis of satisfactory evidence to be the person(s) whose name(s) is/are subscribed to the within instrument and acknowledged to me that he/she/they executed the same in his/her/their authorized capacity(ies), and that by his/her/their signature(s) on the instrument the person(s), or the entity upon behalf of which the person(s) acted, executed the instrument.

I certify under PENALTY OF PERJURY under the laws of the State of California that the foregoing paragraph is true and correct.

WITNESS my hand and official seal.

Signature \_\_\_\_\_

(Seal)

NOTARIES: ATTACH ADDITIONAL OR OTHER FORMS, IF REQUIRED

### ACKNOWLEDGMENT FORM (FOR COUNTY USE ONLY)

STATE OF CALIFORNIA )  
 )  
COUNTY OF LOS ANGELES ) ss.

On March 30, 2011, before me, DEAN C. LOGAN, Registrar-Recorder/County Clerk of the County of Los Angeles, personally appeared STEVEN G. STEINHOFF

\_\_\_\_\_ who proved to me on the basis of satisfactory evidence to be the person(s) whose name(s) is/are subscribed to the within instrument and acknowledged to me that he/she/they executed the same in his/her/their authorized capacity(ies), and that by his/her/their signature(s) on the instrument the person(s), or the entity upon behalf of which the person(s) acted, executed the instrument.

I certify under PENALTY OF PERJURY under the laws of the State of California that the foregoing paragraph is true and correct.

WITNESS my hand and official seal.

DEAN C. LOGAN, Registrar-Recorder/  
County Clerk of the County of Los Angeles

By Allen R. Husted  
Deputy County Clerk

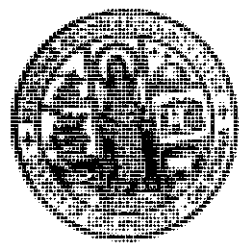

(Seal)

APPROVED as to title and execution,  
  
March 30, 20 11  
DEPARTMENT OF PUBLIC WORKS  
Survey/Mapping & Property Management Division  
Supervising Title Examiner  
  
By Allen R. Husted

**CERTIFICATE OF ACCEPTANCE**  
  
This is to certify that the interest in real property conveyed by the within deed or grant is hereby accepted under the authority conferred by Ordinance No. 95-0052, duly and regularly adopted by the Board of Supervisors of the County of Los Angeles on the 26th day of September 1995, and the Grantee consents to the recordation thereof by its duly authorized officer.  
  
Dated 3/30/11  
By [Signature]  
ASSISTANT DEPUTY DIRECTOR  
Survey/Mapping & Property Management Division

**P S O M A S****LEGAL DESCRIPTION****ACCESS ROAD & BIKING TRAIL EASEMENTS****Parcel 1**

A strip of land, 16 feet wide, over those portions of Parcels 7 and 8 of Parcel Map No. 25802, in the Unincorporated Territory of the County of Los Angeles, as per map filed in Book 338, Pages 23 through 48, inclusive, of Parcel Maps, Records of said County; and those portions of Lots 358, 385, and 394 of Tract No. 52455-01, in said County, as per map filed in Book 1323, Pages 43 through 73, inclusive, of Maps, of said Records, the northerly and westerly line of which is described as follows:

Commencing at the northwesterly corner of said Parcel 7; thence along the northerly line of said Parcel, South 77 degrees 51 minutes 16 seconds East 170.11 feet; thence leaving said northerly line, South 12 degrees 08 minutes 44 seconds West 43.21 feet; thence South 31 degrees 48 minutes 04 seconds West 3.49 feet to the beginning of a curve, concave to the north and having a radius of 40.00 feet; thence westerly 69.19 feet along said curve through a central angle of 99 degrees 06 minutes 07 seconds; thence North 49 degrees 05 minutes 49 seconds West 49.04 feet to the beginning of a curve, concave southerly, and having a radius of 70.00 feet; thence northwesterly 34.70 feet along said curve, through a central angle of 28 degrees 24 minutes 17 seconds; thence North 77 degrees 30 minutes 06 seconds West 36.23 feet to the generally easterly line of said Lot 385, and the True Point of Beginning of this description; thence North 77 degrees 30 minutes 06 seconds West 10.77 feet to the beginning of a curve, concave to the south and having a radius of 40.00 feet; thence westerly 38.13 feet along said curve through a central angle of 54 degrees 36 minutes 58 seconds; thence South 47 degrees 52 minutes 56 seconds West 38.77 feet to a point hereinafter referred to as Point A; thence

Sheet 1 of 10

v:\northriv\proddata\52455\area\_c\survey\legals\flood control legals\access road  
legals\access\_biking.doc  
July 6, 2009  
tpp:rc0

**P S O M A S**

1 || continuing, South 47 degrees 52 minutes 56 seconds West 241.05 feet to the beginning of  
 2 || a curve, concave to the northwest and having a radius of 342.00 feet; thence  
 3 || southwesterly 19.72 feet along said curve, through a central angle of 3 degrees 18 minutes  
 4 || 17 seconds to a point hereinafter referred to as Point B; thence continuing southwesterly  
 5 || 30.46 feet along said curve, through a central angle of 5 degrees 06 minutes 10 seconds to  
 6 || the beginning of a reverse curve, concave to the southeast and having a radius of 408.00  
 7 || feet; thence southwesterly 109.91 feet along said curve through a central angle of 15  
 8 || degrees 26 minutes 03 seconds to the beginning of a reverse curve, concave to the  
 9 || northwest and having a radius of 642.00 feet; thence southwesterly 157.62 feet along said  
 10 || curve through a central angle of 14 degrees 04 minutes 01 seconds to the beginning of a  
 11 || reverse curve, concave to the southeast and having a radius of 408.00 feet; thence  
 12 || southwesterly 108.21 feet along said curve through a central angle of 15 degrees 11  
 13 || minutes 46 seconds to the beginning of a reverse curve, concave to the northwest and  
 14 || having a radius of 392.00 feet; thence southwesterly 55.80 feet along said curve through a  
 15 || central angle of 08 degrees 09 minutes 21 seconds; thence South 47 degrees 52 minutes  
 16 || 56 seconds West 132.65 feet to the beginning of a curve, concave to the southeast and  
 17 || having a radius of 518.00 feet; thence southwesterly 10.10 feet along said curve through a  
 18 || central angle of 01 degrees 07 minutes 01 seconds to a point hereinafter referred to as  
 19 || Point C; thence continuing southwesterly 224.91 feet along said curve, through a central  
 20 || angle of 24 degrees 52 minutes 37 seconds; thence South 21 degrees 53 minutes 18  
 21 || seconds West 230.71 feet to the beginning of a curve, concave westerly, and having a  
 22 || radius of 434.00 feet; thence southwesterly 69.88 feet along the curve, through a central  
 23 || angle of 09 degrees 13 minutes 33 seconds to the beginning of a reverse curve, concave to  
 24 || the southeast and having a radius of 321.00 feet; thence southwesterly 86.02 feet along  
 25 || said curve through a central angle of 15 degrees 21 minutes 16 seconds to the beginning  
 26 || of a reverse curve, concave to the west and having a radius of 2,259.00 feet; thence  
 27 || southerly 134.40 feet along said curve through a central angle of 03 degrees 24 minutes  
 28 || 32 seconds; thence South 19 degrees 10 minutes 07 seconds West 74.41 feet to the

Sheet 2 of 10

v:\northriv\proddata\52455\area\_e\survey\legals\flood control legals\access road  
 legals\access\_biking.doc  
 July 6, 2009  
 tpp:rco



## PSOMAS

---

1 beginning of a curve, concave to the east and having a radius of 516.00 feet; thence  
2 southerly 64.25 feet along said curve through a central angle of 07 degrees 08 minutes 03  
3 seconds to the beginning of a reverse curve, concave to the west and having a radius of  
4 742.00 feet; thence southerly 100.47 feet along said curve through a central angle of 07  
5 degrees 45 minutes 30 seconds to the beginning of a reverse curve, concave to the east  
6 and having a radius of 516.00 feet; thence southerly 109.17 feet along said curve through  
7 a central angle of 12 degrees 07 minutes 21 seconds to the beginning of a reverse curve,  
8 concave to the west and having a radius of 584.00 feet; thence southerly 164.90 feet along  
9 said curve through a central angle of 16 degrees 10 minutes 43 seconds to the beginning  
10 of a reverse curve, concave to the east and having a radius of 290.00 feet; thence  
11 southerly 94.77 feet along said curve through a central angle of 18 degrees 43 minutes 24  
12 seconds to the beginning of a reverse curve, concave to the west and having a radius of  
13 420.00 feet; thence southerly 127.75 feet along said curve through a central angle of 17  
14 degrees 25 minutes 37 seconds to the beginning of a reverse curve, concave to the east  
15 and having a radius of 490.00 feet; thence southerly 113.75 feet along said curve through  
16 a central angle of 13 degrees 18 minutes 01 seconds to the beginning of a reverse curve,  
17 concave to the west and having a radius of 494.00 feet; thence southerly 83.38 feet along  
18 said curve through a central angle of 09 degrees 40 minutes 16 seconds; thence South 18  
19 degrees 55 minutes 24 seconds West 401.75 feet to a point hereinafter referred to as Point  
20 D; thence continuing South 18 degrees 55 minutes 24 seconds West 199.50 feet to the  
21 beginning of a curve, concave to the northwest and having a radius of 142.00 feet; thence  
22 southwesterly 77.32 feet along said curve through a central angle of 31 degrees 11  
23 minutes 59 seconds to the beginning of a reverse curve, concave to the southeast and  
24 having a radius of 158.00 feet; thence southwesterly 72.22 feet along said curve through a  
25 central angle of 26 degrees 11 minutes 18 seconds; thence South 23 degrees 56 minutes  
26 05 seconds West 48.72 feet to the beginning of a curve, concave to the northwest and  
27 having a radius of 142.00 feet; thence southwesterly 118.04 feet along said curve through  
28 a central angle of 47 degrees 37 minutes 48 seconds to the beginning of a reverse curve,

Sheet 3 of 10

v:\northriv\proddata\52455\area\_c\survey\legals\flood control legals\access road  
legals\access\_biking.doc  
July 6, 2009  
tpp:rc0

**P S O M A S**

1 || concave to the southeast and having a radius of 86.00 feet; thence southwesterly 144.08  
2 feet along said curve through a central angle of 95 degrees 59 minutes 28 seconds; thence  
3 South 24 degrees 25 minutes 35 seconds East 215.89 feet to the beginning of a curve,  
4 || concave to the west and having a radius of 157.00 feet; thence southerly 117.99 feet along  
5 said curve through a central angle of 43 degrees 03 minutes 36 seconds to the beginning  
6 of a reverse curve, concave to the east and having a radius of 516.00 feet; thence  
7 southerly 153.97 feet along said curve through a central angle of 17 degrees 05 minutes  
8 48 seconds to the beginning of a reverse curve, concave to the west and having a radius of  
9 384.00 feet; thence southerly 53.13 feet along said curve through a central angle of 07  
10 degrees 55 minutes 37 seconds; thence South 09 degrees 27 minutes 50 seconds West  
11 254.35 feet to the beginning of a curve, concave to the west and having a radius of 242.00  
12 feet; thence southerly 3.86 feet along said curve through a central angle of 00 degrees 54  
13 minutes 54 seconds; thence South 73 degrees 46 minutes 19 seconds West 22.21 feet to a  
14 point hereinafter referred to as Point E; thence South 17 degrees 50 minutes 04 seconds  
15 East 6.31 feet to the beginning of a curve, concave to the west, and having a radius of  
16 75.00 feet; thence southerly 60.19 feet along said curve through a central angle of 45  
17 degrees 58 minutes 52 seconds to the beginning of a compound curve, concave to the  
18 northwest and having a radius of 242.00 feet; thence southwesterly 65.58 feet along said  
19 curve through a central angle of 15 degrees 31 minutes 34 seconds; thence South 43  
20 degrees 40 minutes 22 seconds West 160.48 feet to the beginning of a curve, concave to  
21 the east and having a radius of 258.00 feet; thence southerly 192.39 feet along said curve  
22 through a central angle of 42 degrees 43 minutes 34 seconds; thence South 00 degrees 56  
23 minutes 48 seconds West 273.93 feet to the beginning of a curve, concave to the  
24 northwest and having a radius of 192.00 feet; thence southwesterly 185.61 feet along said  
25 curve through a central angle of 55 degrees 23 minutes 17 seconds to the beginning of a  
26 reverse curve, concave to the southeast and having a radius of 258.00 feet; thence  
27 southwesterly 220.90 feet along said curve through a central angle of 49 degrees 03  
28 minutes 28 seconds to the beginning of a reverse curve, concave to the northwest and

Sheet 4 of 10

v:\northriv\proddata\52455\area\_c\survey\legals\flood control legals\access road  
legals\access\_biking.doc  
July 6, 2009  
tpp:rc0

**P S O M A S**

---

1 having a radius of 242.00 feet; thence southwesterly 147.04 feet along said curve through  
2 a central angle of 34 degrees 48 minutes 48 seconds to the beginning of a reverse curve,  
3 concave to the east and having a radius of 208.00 feet; thence southerly 188.41 feet along  
4 said curve through a central angle of 51 degrees 53 minutes 57 seconds; thence South 09  
5 degrees 48 minutes 32 seconds East 236.46 feet to the beginning of a curve, concave to  
6 the west and having a radius of 192.00 feet; thence southerly 113.04 feet along said curve  
7 through a central angle of 33 degrees 44 minutes 02 seconds; thence South 23 degrees 55  
8 minutes 30 seconds West 81.13 feet to the beginning of a curve, concave to the east and  
9 having a radius of 208.00 feet; thence southerly 55.38 feet along said curve through a  
10 central angle of 15 degrees 15 minutes 19 seconds; thence South 08 degrees 40 minutes  
11 11 seconds West 106.46 feet to the beginning of a curve, concave to the west and having  
12 a radius of 142.00 feet; thence southerly 28.82 feet along said curve through a central  
13 angle of 11 degrees 37 minutes 39 seconds; thence South 20 degrees 17 minutes 50  
14 seconds West 58.08 feet to the beginning of a curve, concave to the east and having a  
15 radius of 88.00 feet; thence southerly 93.17 feet along said curve through a central angle  
16 of 60 degrees 39 minutes 48 seconds; thence South 40 degrees 21 minutes 58 seconds  
17 East 24.32 feet to the beginning of a curve, concave to the northeast and having a radius  
18 of 123.00 feet; thence southeasterly 21.90 feet along said curve through a central angle of  
19 10 degrees 12 minutes 01 seconds; thence South 50 degrees 33 minutes 59 seconds East  
20 25.64 feet to the beginning of a curve, concave to the southwest and having a radius of  
21 142.00 feet; thence southeasterly 124.45 feet along said curve through a central angle of  
22 50 degrees 12 minutes 52 seconds to the beginning of a reverse curve, concave to the east  
23 and having a radius of 258.00 feet; thence southerly 25.50 feet along said curve through a  
24 central angle of 05 degrees 39 minutes 45 seconds; thence South 06 degrees 00 minutes  
25 52 seconds East 24.65 feet to the beginning of a curve, concave to the west and having a  
26 radius of 242.00 feet; thence southerly 20.38 feet along said curve through a central angle  
27 of 04 degrees 49 minutes 32 seconds; thence South 01 degrees 11 minutes 20 seconds  
28 East 54.72 feet to the beginning of a curve, concave to the northeast and having a radius

Sheet 5 of 10

v:\northriv\proddata\52455\area\_c\survey\legals\flood control legals\access road  
legals\access\_biking.doc  
July 6, 2009  
tpp:rc0





**P S O M A S**

---

1 of 158.00 feet; thence southeasterly 137.09 feet along said curve through a central angle  
2 of 49 degrees 42 minutes 41 seconds; thence South 50 degrees 54 minutes 01 seconds  
3 East 80.29 feet to a point hereinafter referred to as Point F.

4  
5  
6  
7 : Parcel 2

8  
9 A strip of land, 16 feet wide, over that portion of Lot 385 of Tract No. 52455-01, in the  
10 Unincorporated Territory of the County of Los Angeles, as per map filed in Book 1323,  
11 Pages 43 through 73, inclusive, of Maps, Records of said County, the center line of which  
12 is described as follows:

13  
14 Beginning at the hereinabove described Point A; thence North 17 degrees 27 minutes 52  
15 seconds West 57.92 feet to the beginning of a curve, concave easterly, and having a  
16 radius of 45.00 feet; thence northerly 23.51 feet along said curve, through a central angle  
17 of 29 degrees 55 minutes 40 seconds; thence North 12 degrees 27 minutes 48 seconds  
18 East 10.87 feet to the southerly line of Copper Hill Drive, 100 feet wide, as shown on said  
19 tract.

20  
21  
22 : Parcel 3

23  
24 That portion of Parcel 8 of Parcel Map No. 25802, in the Unincorporated Territory of the  
25 County of Los Angeles, as per map filed in Book 338, Pages 23 through 48, inclusive, of  
26 Parcel Maps, Records of said County, and that portion of Decoro Drive, 86 feet wide, as  
27 shown on said Parcel Map and being more particularly described as follows:

**P S O M A S**

1 Beginning at the hereinabove described Point E; thence South 73 degrees 31 minutes 13  
2 seconds East 205.50 feet to the beginning of a curve, concave to the southwest and having  
3 a radius of 35.00 feet; thence southeasterly 50.81 feet along said curve through a central  
4 angle of 83 degrees 10 minutes 48 seconds; thence South 09 degrees 39 minutes 35  
5 seconds West 125.65 feet to the beginning of a curve, concave to the northwest and  
6 having a radius of 35.00 feet; thence southwesterly 32.06 feet along said curve through a  
7 central angle of 52 degrees 29 minutes 13 seconds; thence South 62 degrees 08 minutes  
8 48 seconds West 142.90 feet to the beginning of a non-tangent curve, concave to the  
9 northwest, having a radius of 108.00 feet and to which beginning a radial line bears South  
10 76 degrees 29 minutes 49 seconds East; thence southwesterly 43.09 feet along said curve  
11 through a central angle of 22 degrees 51 minutes 35 seconds; thence South 36 degrees 21  
12 minutes 46 seconds West 43.50 feet to the beginning of a curve, concave to the northwest  
13 and having a radius of 108.00 feet; thence southwesterly 35.13 feet along said curve  
14 through a central angle of 18 degrees 38 minutes 11 seconds; thence South 54 degrees 59  
15 minutes 57 seconds West 239.55 feet to the beginning of a curve, concave to the north  
16 and having a radius of 60.00 feet; thence westerly 25.98 feet along said curve through a  
17 central angle of 24 degrees 48 minutes 27 seconds; thence South 79 degrees 48 minutes  
18 24 seconds West 20.07 feet to the beginning of a curve, concave to the southeast and  
19 having a radius of 60.00 feet; thence southwesterly 11.77 feet along said curve through a  
20 central angle of 11 degrees 14 minutes 18 seconds to the beginning of a compound curve,  
21 concave southeasterly, having a radius of 27.00 feet and being tangent at its southerly  
22 terminus with a line which bears South 02 degrees 50 minutes 47 seconds West and  
23 passes through a point on the southerly line of said Parcel 8, distant thereon South 87  
24 degrees 20 minutes 37 seconds East 54.83 feet from the easterly right of way line of  
25 Dickason Drive, 84 feet wide, as shown on said Parcel Map; thence southwesterly and  
26 southerly 30.97 feet along said curve through a central angle of 65 degrees 43 minutes 19  
27 seconds to said tangent line; thence North 02 degrees 50 minutes 47 seconds East 89.01  
28 feet to the beginning of a curve concave easterly and having a radius of 92.00 feet;

Sheet 7 of 10

v:\northriv\proddata\52455\area\_c\survey\legals\flood control legals\access road  
legals\access\_biking.doc  
July 6, 2009  
tpp:rc0



## PSOMAS

---

1 || thence northerly 8.86 feet along said curve through a central angle of 5 degrees 31  
 2 minutes 12 seconds to a point of cusp with a curve concave northeasterly having a radius  
 3 || of 41.00 feet and being tangent at its northeasterly terminus with a line which bears  
 4 North 54 degrees 59 minutes 57 seconds East and is parallel with and 16.00 feet  
 5 | northwesterly of the hereinbefore described line having a bearing and length of South 54  
 6 degrees 59 minutes 57 seconds West 239.55 feet, and to which point a radial line bears  
 7 North 81 degrees 38 minutes 01 seconds West; thence southeasterly 95.44 feet along said  
 8 | curve through a central angle of 133 degrees 22 minutes 02 seconds to said tangent line;  
 9 thence along said tangent line, North 54 degrees 59 minutes 57 seconds East 231.51 feet  
 10 to the beginning of a curve, concave to the northwest and having a radius of 92.00 feet;  
 11 thence northeasterly 29.92 feet along said curve through a central angle of 18 degrees 38  
 12 | minutes 11 seconds; thence North 36 degrees 21 minutes 46 seconds East 43.45 feet to  
 13 the beginning of a curve, concave to the northwest and having a radius of 92.00 feet;  
 14 || thence northeasterly 39.96 feet along said curve through a central angle of 24 degrees 53  
 15 | minutes 03 seconds; thence North 11 degrees 28 minutes 43 seconds East 3.84 feet;  
 16 thence North 62 degrees 08 minutes 48 seconds East 91.38 feet; thence North 66 degrees  
 17 || 01 minutes 21 seconds East 57.66 feet to the beginning of a curve, concave to the  
 18 northwest and having a radius of 23.00 feet; thence northeasterly 22.63 feet along said  
 19 || curve through a central angle of 56 degrees 21 minutes 46 seconds; thence North 09  
 20 degrees 39 minutes 35 seconds East 125.51 feet to the beginning of a curve, concave to  
 21 the southwest and having a radius of 23.00 feet; thence northwesterly 35.28 feet along  
 22 said curve through a central angle of 87 degrees 53 minutes 11 seconds; thence North 78  
 23 | degrees 13 minutes 36 seconds West 46.86 feet; thence North 73 degrees 31 minutes 13  
 24 seconds West 118.51 feet to a line which bears South 50 degrees 54 minutes 01 seconds  
 25 | East and passes through the herein before described Point F; thence North 50 degrees 54  
 26 minutes 01 seconds West 41.60 feet to said Point F and the point of beginning.  
 27 |  
 28

Sheet 8 of 10

v:\northriv\proddata\52455\area\_c\survey\legals\flood control legals\access road  
 legals\access\_biking.doc  
 July 6, 2009  
 tpp:rc0

116

**P S O M A S**

---

1 || Parcel 4

2

3 || That portion of Parcel 8 of Parcel Map No. 25802, in the Unincorporated Territory of the  
4 County of Los Angeles, as per map filed in Book 338, Pages 23 through 48, inclusive, of  
5 Parcel Maps, Records of said County, and being more particularly described as follows:

6

7 Beginning at point on the southerly line of said Parcel 8 distant thereon South 87 degrees  
8 20 minutes 37 seconds East 54.83 feet from the easterly right of way line of Dickason  
9 Drive, 84 feet wide, as shown on said Parcel Map; thence along said southerly line North  
10 87 degrees 20 minutes 37 seconds West 16.00 feet; thence North 02 degrees 50 minutes  
11 47 seconds East 95.69 feet to the beginning of a curve, concave to the east and having a  
12 radius of 108.00 feet; thence northerly 30.71 feet along said curve through a central angle  
13 of 16 degrees 17 minutes 28 seconds; thence North 19 degrees 08 minutes 15 seconds  
14 East 123.89 feet to the beginning of a curve, concave to the west and having a radius of  
15 92.00 feet; thence northerly 26.75 feet along said curve through a central angle of 16  
16 degrees 39 minutes 33 seconds; thence North 02 degrees 28 minutes 42 seconds East  
17 148.76 feet to the southerly line of Decoro Drive, 86 feet wide, as shown on said Parcel  
18 Map; thence along said southerly line, South 87 degrees 20 minutes 30 seconds East  
19 16.00 feet; thence leaving said southerly line, South 02 degrees 28 minutes 42 seconds  
20 West 148.71 feet to the beginning of a curve, concave to the west and having a radius of  
21 108.00 feet; thence southerly 31.40 feet along said curve through a central angle of 16  
22 degrees 39 minutes 33 seconds; thence South 19 degrees 08 minutes 15 seconds West  
23 123.89 feet to the beginning of a curve, concave to the east, having a radius of 92.00 feet  
24 and being tangent at its southerly terminus with a line which bears North 2 degrees 50  
25 minutes 47 seconds East and passes through the Point of Beginning; thence southerly  
26 26.16 feet along said curve through a central angle of 16 degrees 17 minutes 28 seconds;  
27 thence South 02 degrees 50 minutes 47 seconds West 95.64 feet to the point of beginning.

28

17

**PSOMAS**

1 The side lines of said Parcel 1 are to be extended or shortened so as to terminate  
 2 northeasterly in said generally easterly line of Lot 385; to terminate southerly in the  
 3 northerly side line of the hereinabove described Parcel 3; and the easterly side line which  
 4 adjoins that certain curve in the westerly line of Parcel 1, described hereon as having a  
 5 radius of 242.00 feet, a length of 65.58 feet, and shown as curve number C37 on Sheet 5  
 6 of 10 on the attached Exhibit Map, shall be continued northeasterly to a point of tangency  
 7 with the easterly side line which adjoins that certain course in the westerly line of Parcel 1  
 8 described hereon as having a bearing and length of South 9 degrees 27 minutes 50  
 9 seconds West 254.35 feet and shown as line number L24 on Sheet 5 of 10 on the attached  
 10 Exhibit Map.

11  
 12  
 13  
 14  
 15  
 16  
 17  
 18  
 19  
 20  
 21  
 22  
 23  
 24  
 25  
 26  
 27  
 28

The side lines of said Parcel 2 is to be extended or shortened so as to terminate northerly  
 in the southerly line of said Copper Hill Drive, and to terminate southerly in the  
 northwesterly side line of said Parcel 1.

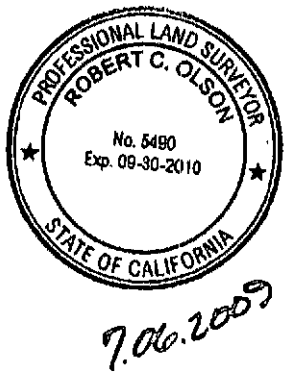

Prepared under the direction of

A handwritten signature in cursive script that reads "Robert C. Olson".

Robert C. Olson, PLS 5490  
 PSOMAS

# EXHIBIT MAP

"ACCESS ROAD & BIKING TRAIL EASEMENTS"  
 IN THE UNINCORPORATED TERRITORY OF  
 THE COUNTY OF LOS ANGELES, STATE OF CALIFORNIA  
 SUPPLEMENTAL EXHIBIT TO LEGAL DESCRIPTION - JOB NO: 1VAL021965

\*SEE SHEET 10 FOR EASEMENT DESCRIPTIONS\*

TRACT NO. 52455-01  
 M.B. 1323-43-73

EQUESTRIAN & HIKING TRAIL  
 EASEMENT TO BE RECORDED  
 BY SEPARATE DOCUMENT

SCALE: 1"=100'

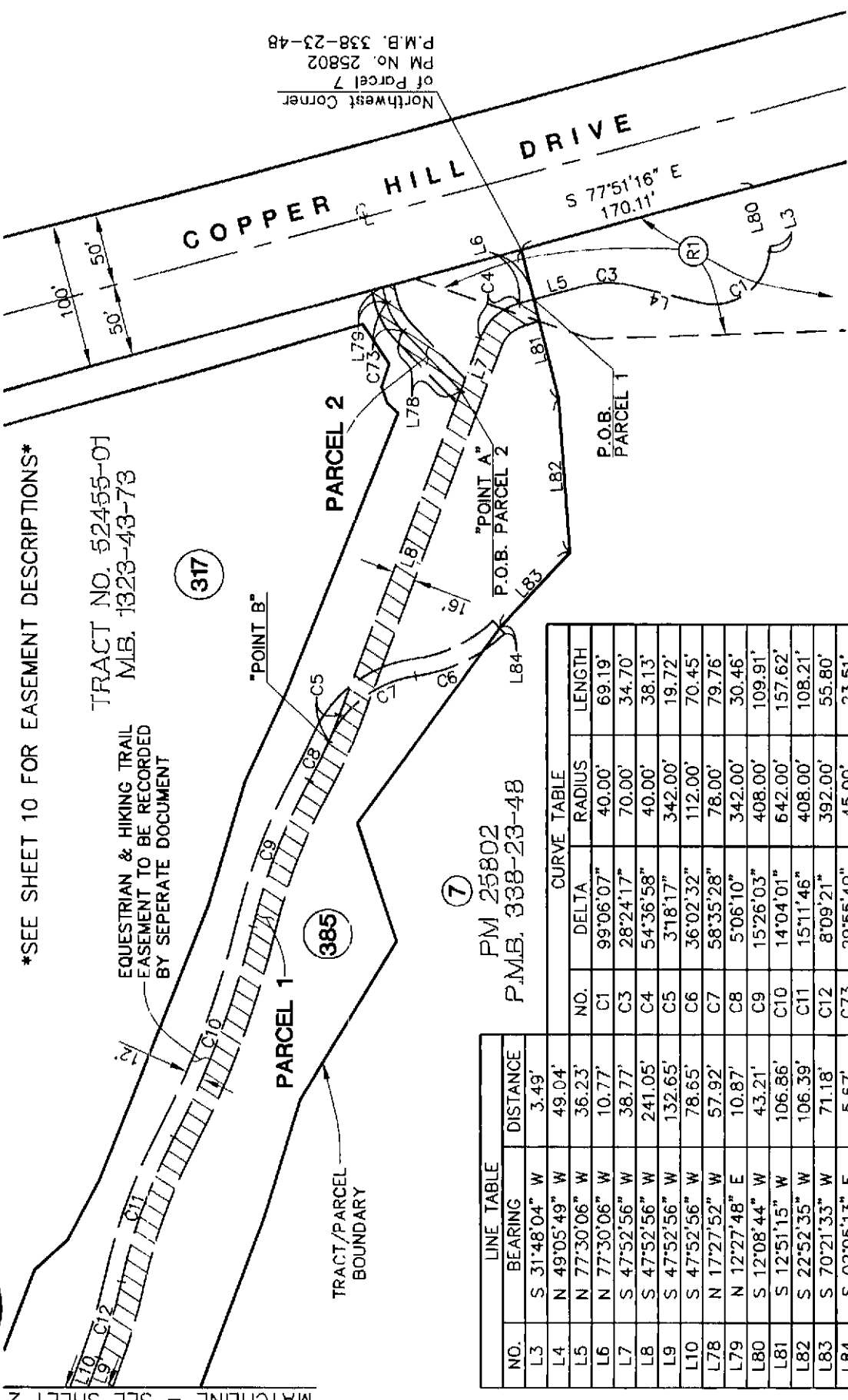

LINE TABLE			CURVE TABLE			
NO.	BEARING	DISTANCE	NO.	DELTA	RADIUS	LENGTH
L3	S 31°48'04" W	3.49'	C1	99°06'07"	40.00'	69.19'
L4	N 49°05'49" W	49.04'	C3	28°24'17"	70.00'	34.70'
L5	N 77°30'06" W	36.23'	C4	54°36'58"	40.00'	38.13'
L6	N 77°30'06" W	10.77'	C5	318'17"	342.00'	19.72'
L7	S 47°52'56" W	38.77'	C6	36°02'32"	112.00'	70.45'
L8	S 47°52'56" W	241.05'	C7	58°35'28"	78.00'	79.76'
L9	S 47°52'56" W	132.65'	C8	5°06'10"	342.00'	30.46'
L10	S 47°52'56" W	78.65'	C9	15°26'03"	408.00'	109.91'
L78	N 17°27'52" W	57.92'	C10	14°04'01"	642.00'	157.62'
L79	N 12°27'48" E	10.87'	C11	15°11'46"	408.00'	108.21'
L80	S 12°08'44" W	43.21'	C12	8°09'21"	392.00'	55.80'
L81	S 12°51'15" W	106.86'	C73	29°55'40"	45.00'	23.51'
L82	S 22°52'35" W	106.39'				
L83	S 70°21'33" W	71.18'				
L84	S 02°05'13" E	5.67'				

PM 25802  
 P.M.B. 338-23-48

**PSOMAS**

SHEET 2 OF 10

# EXHIBIT MAP

"ACCESS ROAD & BIKING TRAIL EASEMENTS"  
 IN THE UNINCORPORATED TERRITORY OF  
 THE COUNTY OF LOS ANGELES, STATE OF CALIFORNIA  
 SUPPLEMENTAL EXHIBIT TO LEGAL DESCRIPTION - JOB NO: 1VAL021965

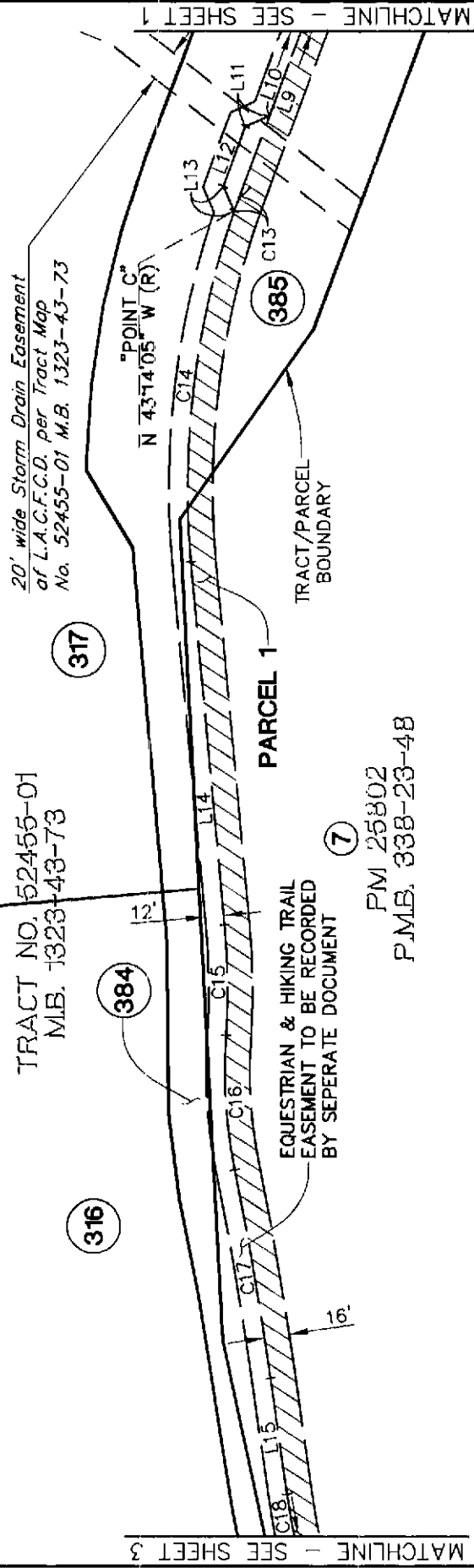
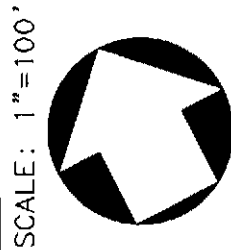

LINE TABLE		CURVE TABLE				
NO.	BEARING	DISTANCE	NO.	DELTA	RADIUS	LENGTH
L9	S 47°52'56" W	132.65'	C13	1°07'01"	518.00'	10.10'
L10	S 47°52'56" W	78.65'	C14	24°52'37"	518.00'	224.91'
L11	N 87°07'04" W	16.97'	C15	9°13'33"	434.00'	69.88'
L12	S 47°52'31" W	40.00'	C16	15°21'16"	321.00'	86.02'
L13	S 02°52'56" W	17.10'	C17	3°24'32"	2259.00'	134.40'
L14	S 21°53'18" W	230.71'	C18	7°08'03"	516.00'	64.25'
L15	S 19°10'07" W	74.41'				

# PSOMAS

# EXHIBIT MAP

"ACCESS ROAD & BIKING TRAIL EASEMENTS"  
 IN THE UNINCORPORATED TERRITORY OF  
 THE COUNTY OF LOS ANGELES, STATE OF CALIFORNIA  
 SUPPLEMENTAL EXHIBIT TO LEGAL DESCRIPTION - JOB NO: 1VAL021965

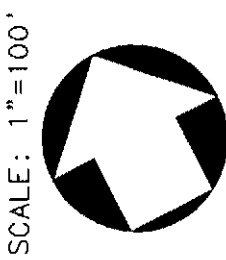

MATCHLINE - SEE SHEET 2

316  
 TRACT NO. 52455-01  
 M.B. 1323-43-73

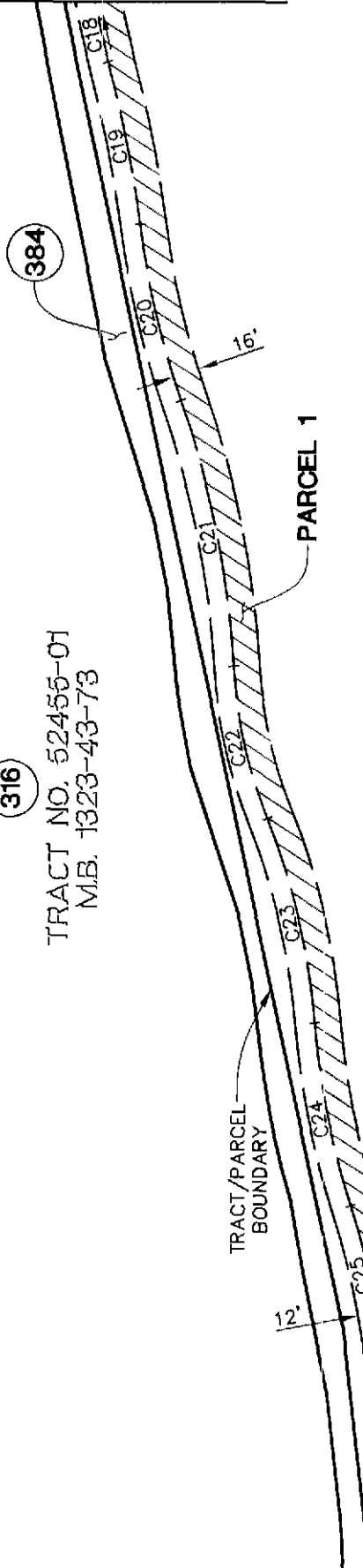

7  
 PM 25802  
 P.M.B. 338-23-48

MATCHLINE - SEE SHEET 4

CURVE TABLE			LINE TABLE			
NO.	DELTA	RADIUS	LENGTH	NO.	BEARING	DISTANCE
C18	7°08'03"	516.00'	54.25'	L16	S 18°55'24" W	401.75'
C19	7°45'30"	742.00'	100.47'	L17	S 18°55'24" W	191.97'
C20	12°07'21"	516.00'	109.17'			
C21	16°10'43"	584.00'	164.90'			
C22	18°43'24"	290.00'	94.77'			
C23	17°25'37"	420.00'	127.75'			
C24	13°18'01"	490.00'	113.75'			
C25	9°40'16"	494.00'	83.38'			

# PSOMAS



# EXHIBIT MAP

"ACCESS ROAD & BIKING TRAIL EASEMENTS"  
 IN THE UNINCORPORATED TERRITORY OF  
 THE COUNTY OF LOS ANGELES, STATE OF CALIFORNIA  
 SUPPLEMENTAL EXHIBIT TO LEGAL DESCRIPTION - JOB NO: 1VAL021965

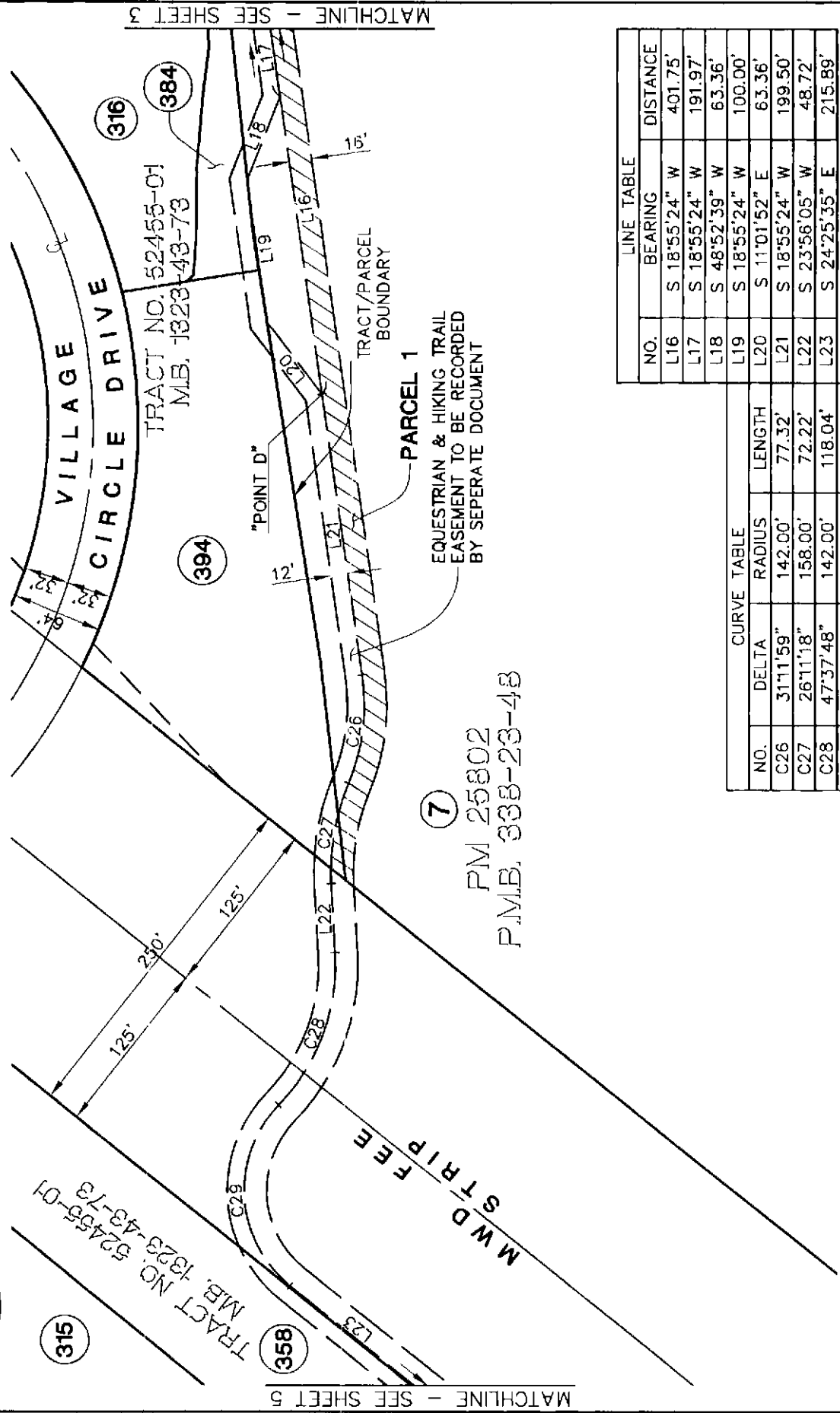
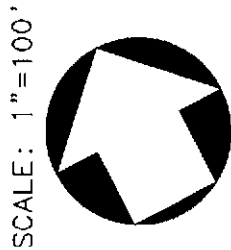

LINE TABLE		
NO.	BEARING	DISTANCE
L16	S 18°55'24" W	401.75'
L17	S 18°55'24" W	191.97'
L18	S 48°52'39" W	63.36'
L19	S 18°55'24" W	100.00'
L20	S 11°01'52" E	63.36'
L21	S 18°55'24" W	199.50'
L22	S 23°56'05" W	48.72'
L23	S 24°25'35" E	215.89'

CURVE TABLE			
NO.	DELTA	RADIUS	LENGTH
C26	31°11'59"	142.00'	77.32'
C27	26°11'18"	158.00'	72.22'
C28	47°37'48"	142.00'	118.04'
C29	95°59'28"	86.00'	144.08'

# PSOMAS

2

# EXHIBIT MAP

"ACCESS ROAD & BIKING TRAIL EASEMENTS"  
 IN THE UNINCORPORATED TERRITORY OF  
 THE COUNTY OF LOS ANGELES, STATE OF CALIFORNIA  
 SUPPLEMENTAL EXHIBIT TO LEGAL DESCRIPTION - JOB NO: 1VAL021965

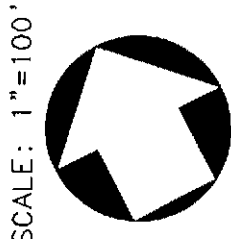

LINE TABLE		CURVE TABLE				
NO.	BEARING	DISTANCE	NO.	DELTA	RADIUS	LENGTH
L23	S 24°25'35" E	215.89'	C30	43°03'36"	157.00'	117.99'
L24	S 09°27'50" W	254.35'	C31	17°05'48"	516.00'	153.97'
L25	S 73°46'19" W	22.21'	C32	7°55'37"	384.00'	53.13'
L26	S 09°27'50" W	77.78'	C33	0°54'54"	242.00'	3.86'
L27	S 44°41'18" W	37.87'	C34	35°13'28"	157.00'	96.52'
L28	S 17°50'04" E	67.84'	C35	62°31'22"	8.00'	8.73'
L29	S 17°50'04" E	6.31'	C36	45°58'52"	75.00'	60.19'
L30	S 43°40'22" W	160.48'	C37	15°31'34"	242.00'	65.58'
			C38	42°43'34"	258.00'	192.39'

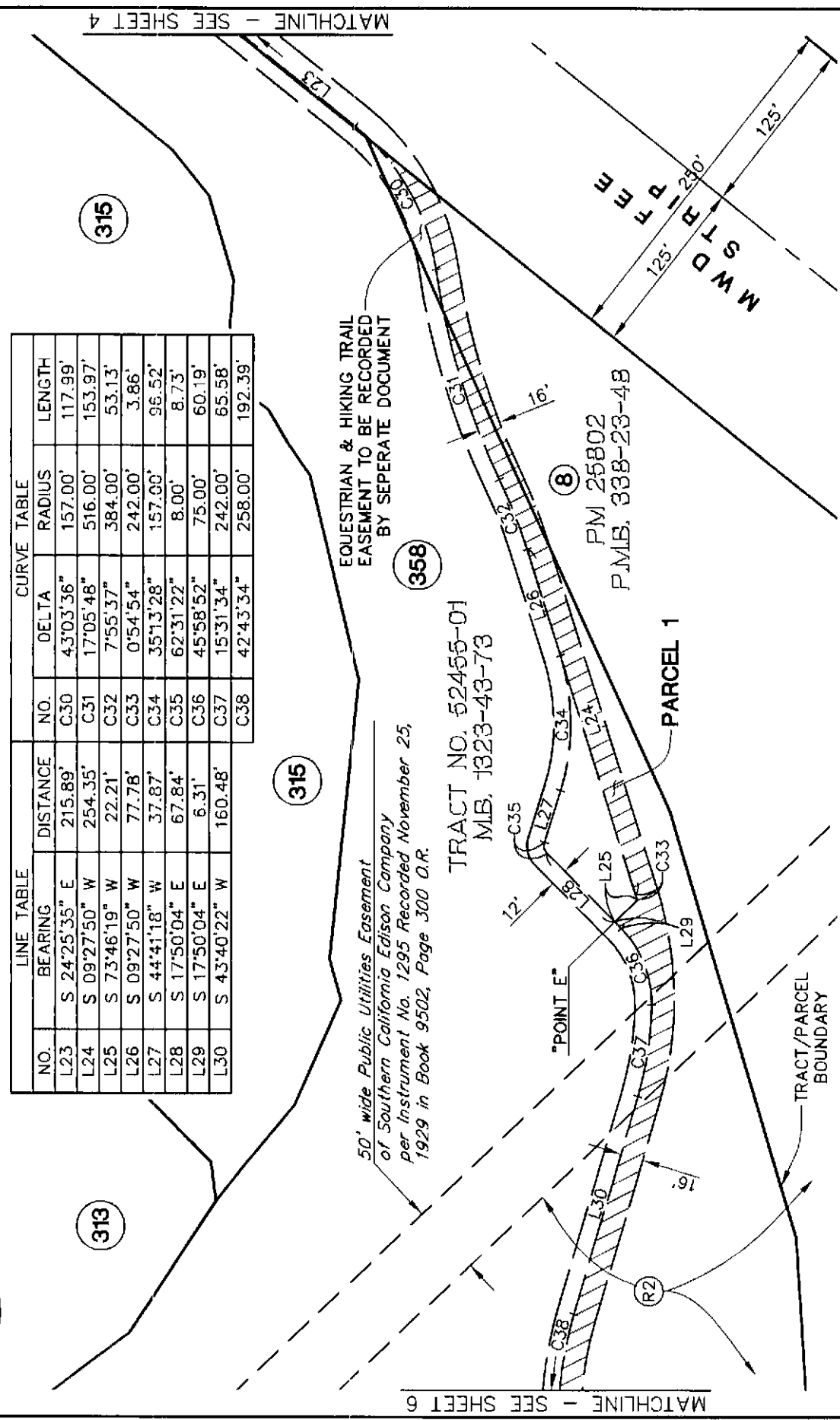

**PSOMAS**

\*SEE SHEET 10 FOR EASEMENT DESCRIPTIONS\*

# EXHIBIT MAP

"ACCESS ROAD & BIKING TRAIL EASEMENTS"  
 IN THE UNINCORPORATED TERRITORY OF  
 THE COUNTY OF LOS ANGELES, STATE OF CALIFORNIA  
 SUPPLEMENTAL EXHIBIT TO LEGAL DESCRIPTION - JOB NO: 1VAL021965

SCALE: 1" = 100'

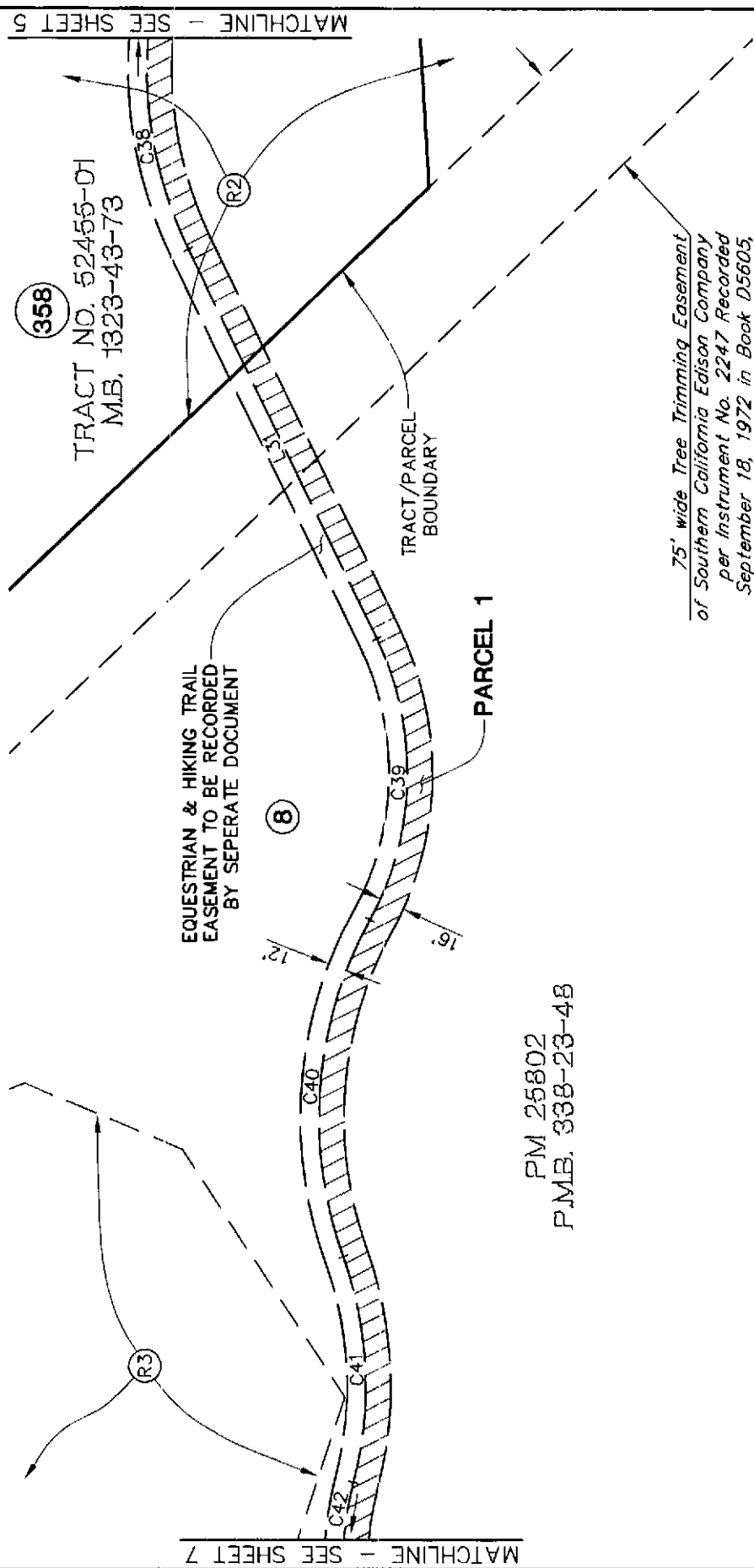
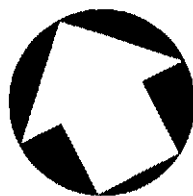

MATCHLINE - SEE SHEET 5

MATCHLINE - SEE SHEET 7

PM 25802  
 P.M.B. 338-23-48

CURVE TABLE		
NO.	DELTA	LENGTH
C38	42°43'34"	192.39'
C39	55°23'17"	185.61'
C40	49°03'28"	220.90'
C41	34°48'48"	147.04'
C42	51°53'57"	188.41'

\*SEE SHEET 10 FOR EASEMENT DESCRIPTIONS\*

LINE TABLE		
NO.	BEARING	DISTANCE
L31	S. 00°56'48" W	273.93'

75' wide Tree Trimming Easement  
 of Southern California Edison Company  
 per Instrument No. 2247 Recorded  
 September 18, 1972 in Book D5605,  
 Page 72 O.R., and Instrument No.  
 548 Recorded November 17, 1969  
 in Book D4456, Page 239 O.R.

# PSOMAS

# EXHIBIT MAP

"ACCESS ROAD & BIKING TRAIL EASEMENTS"  
 IN THE UNINCORPORATED TERRITORY OF  
 THE COUNTY OF LOS ANGELES, STATE OF CALIFORNIA  
 SUPPLEMENTAL EXHIBIT TO LEGAL DESCRIPTION - JOB NO: 1VAL021965

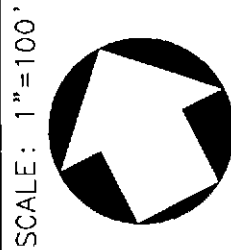

CURVE TABLE			LINE TABLE			
NO.	DELTA	RADIUS	LENGTH	NO.	BEARING	DISTANCE
C42	51°53'57"	208.00'	188.41'	L32	S 09°48'32" E	236.46'
C43	33°44'02"	192.00'	113.04'	L33	S 23°55'30" W	81.13'
C44	15°15'19"	208.00'	55.38'	L34	S 08°40'11" W	106.46'
C45	11°37'39"	142.00'	28.82'	L35	S 20°17'50" W	58.08'
C46	60°39'48"	88.00'	93.17'	L36	S 40°21'58" E	24.32'
C47	10°12'01"	123.00'	21.90'	L37	S 50°33'59" E	25.64'
C48	50°12'52"	142.00'	124.45'			

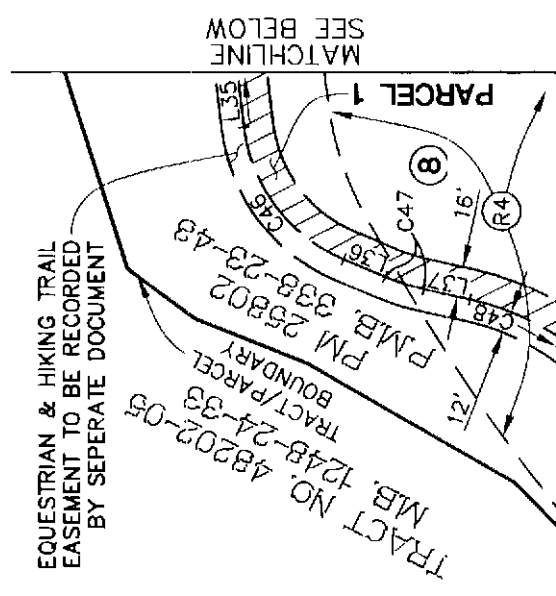

TRACT NO. 48202-05  
 M.B. 1248-24-33

EQUESTRIAN & BIKING TRAIL  
 EASEMENT TO BE RECORDED  
 BY SEPARATE DOCUMENT

20' wide Waterline and  
 Public Utilities Easement  
 of Valencia Water Company  
 per Instrument No.  
 03-1813362 Recorded  
 June 25, 2003 O.R.

PM 25802  
 P.M.B. 338-23-48

# PSOMAS

\*SEE SHEET 10 FOR EASEMENT DESCRIPTIONS\*

SHEET 8 OF 10

# EXHIBIT MAP

"ACCESS ROAD & BIKING TRAIL EASEMENTS"  
 IN THE UNINCORPORATED TERRITORY OF  
 THE COUNTY OF LOS ANGELES, STATE OF CALIFORNIA  
 SUPPLEMENTAL EXHIBIT TO LEGAL DESCRIPTION - JOB NO: 1VAL021965

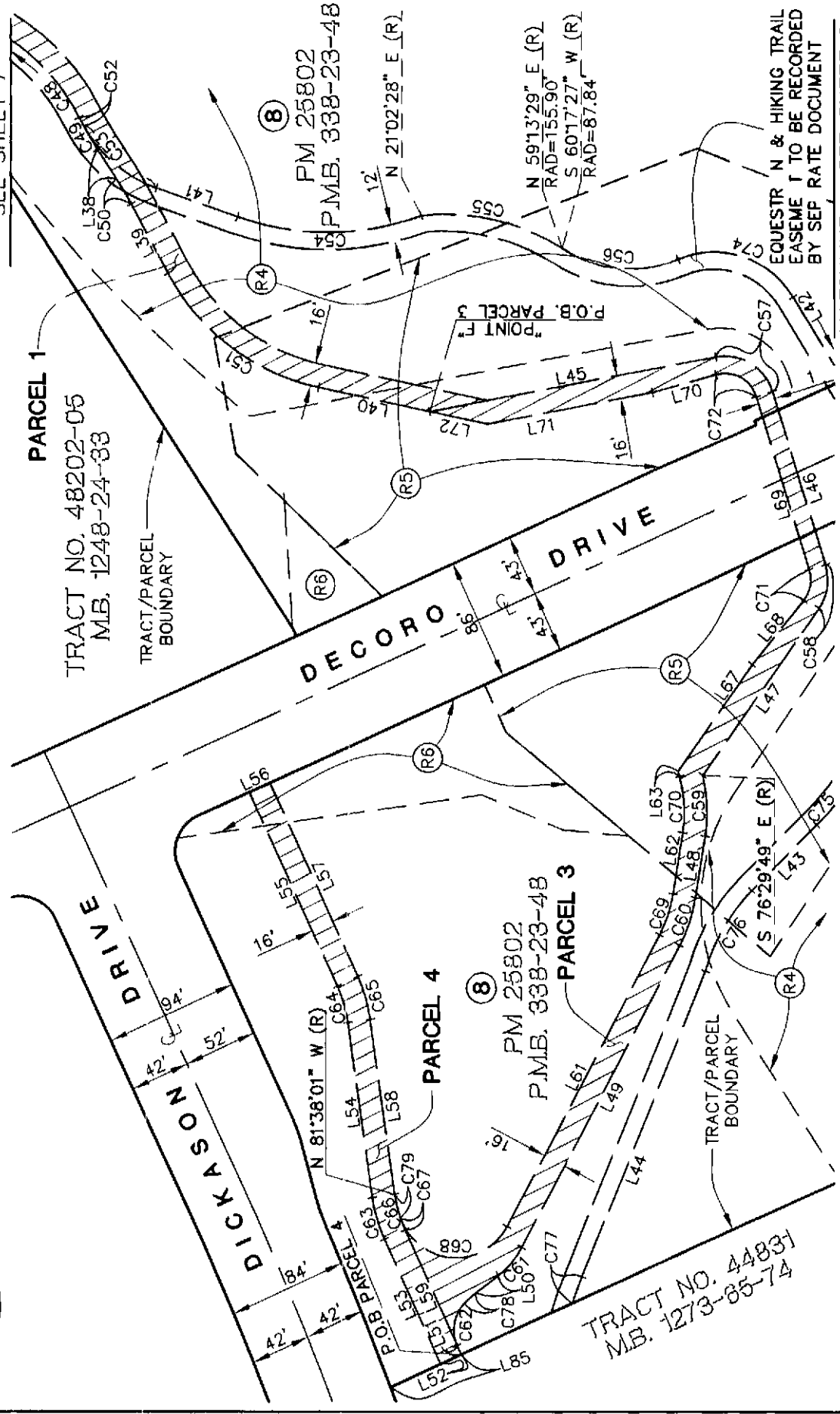
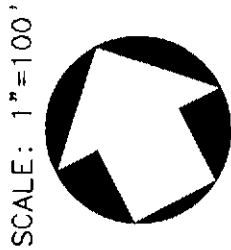

\*\*SEE SHEET 9 FOR LINE AND CURVE DATA\*\*  
 \*\*SEE SHEET 10 FOR EASEMENT DESCRIPTIONS\*\*

MATCHLINE - SEE SHEET 9  
**P S O M A S**

210

# EXHIBIT MAP

"ACCESS ROAD & BIKING TRAIL EASEMENTS"  
 IN THE UNINCORPORATED TERRITORY OF  
 THE COUNTY OF LOS ANGELES, STATE OF CALIFORNIA  
 SUPPLEMENTAL EXHIBIT TO LEGAL DESCRIPTION - JOB NO: 1VAL021965

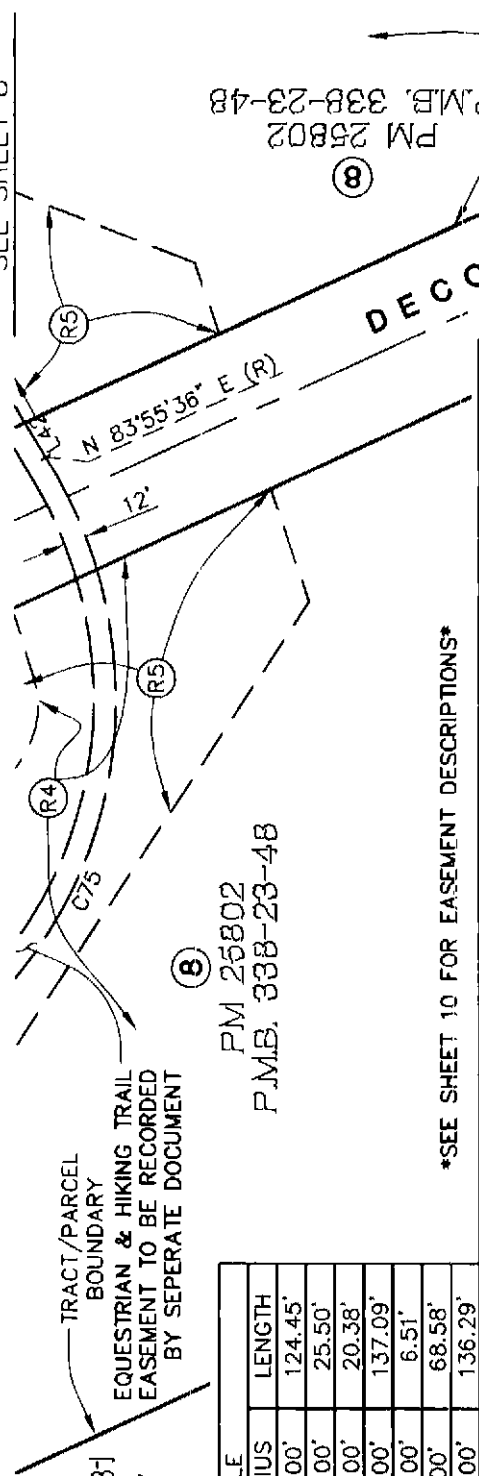
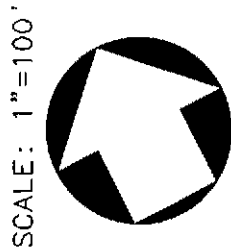

TRACT NO. 44831  
 M.B. 1273-65-74

PM 25802  
 P.M.B. 338-23-48

CURVE TABLE		
NO.	DELTA	RADIUS
C48	50'12'52"	142.00'
C49	5'39'45"	258.00'
C50	4'49'32"	242.00'
C51	49'42'41"	158.00'
C52	1'26'47"	258.00'
C53	41'48'14"	94.00'
C54	40'27'35"	193.00'
C55	93'43'18"	207.00'
C56	52'16'14"	207.00'
C57	83'10'48"	35.00'
C58	52'29'13"	35.00'
C59	22'51'35"	108.00'
C60	18'38'11"	108.00'
C61	24'48'27"	60.00'
C62	65'43'19"	27.00'
C63	16'17'28"	108.00'
C64	16'39'33"	92.00'
C65	16'39'33"	108.00'
C66	16'17'28"	92.00'
C67	5'31'12"	92.00'
C68	133'22'02"	41.00'
C69	18'38'11"	92.00'
C70	24'53'03"	92.00'
C71	56'21'46"	23.00'
C72	87'53'11"	23.00'
C74	81'30'46"	65.07'
C75	78'06'30"	232.78'
C76	29'29'26"	127.82'
C77	3'19'16"	345.97'
C78	11'14'18"	60.00'
C79	10'46'16"	92.00'

\*SEE SHEET 10 FOR EASEMENT DESCRIPTIONS\*

LINE TABLE			LINE TABLE		
NO.	BEARING	DISTANCE	NO.	BEARING	DISTANCE
L38	S 06°00'52" E	24.65'	L61	N 54°59'57" E	231.51'
L39	S 01°11'20" E	54.72'	L62	N 36°21'46" E	43.45'
L40	S 50°54'01" E	80.29'	L63	N 11°28'43" E	3.84'
L41	S 43°36'08" E	60.67'	L67	N 62°08'48" E	91.38'
L42	S 84°03'43" E	179.52'	L68	N 66°01'21" E	57.66'
L43	S 09°39'35" W	254.90'	L69	N 09°39'35" E	125.51'
L44	S 61°55'49" W	170.62'	L70	N 78°13'36" W	46.86'
L45	S 73°31'13" E	205.50'	L71	N 73°31'13" W	118.51'
L46	S 09°39'35" W	125.65'	L72	S 50°54'01" E	41.60'
L47	S 62°08'48" W	142.90'	L85	N 87°20'37" W	54.83'
L48	S 36°21'46" W	43.50'			
L49	S 54°59'57" W	239.55'			
L50	S 79°48'24" W	20.07'			
L51	S 02°50'47" W	6.63'			
L52	N 87°20'37" W	16.00'			
L53	N 02°50'47" E	95.69'			
L54	N 19°08'15" E	123.89'			
L55	N 02°28'42" E	148.76'			
L56	S 87°20'30" E	16.00'			
L57	S 02°28'42" W	148.71'			
L58	S 19°08'15" W	123.89'			
L59	S 02°50'47" W	89.01'			

**PSOMAS**

# EXHIBIT MAP

"ACCESS ROAD & BIKING TRAIL EASEMENTS"  
IN THE UNINCORPORATED TERRITORY OF  
THE COUNTY OF LOS ANGELES, STATE OF CALIFORNIA  
SUPPLEMENTAL EXHIBIT TO LEGAL DESCRIPTION - JOB NO: 1VAL021965

## LEGEND



- Extents of Biking and Access Road Easements Being Conveyed by this Exhibit. (Parcels 1, 2, 3, and 4)

## EASEMENT DESCRIPTIONS:

- (R1) Flood Control Easement of Los Angeles County Flood Control District per Instrument No. 99-1109871 recorded June 16, 1999.
- (R2) 300' wide Public Utilities Easement of Southern California Edison Company per Instrument No. 2247 Recorded September 18, 1972 in Book 05605, Page 724 O.R.
- (R3) Storm Drain Easement of Los Angeles County Flood Control District per Tract Map No. 48202-02, M.B. 1243-33-42.
- (R4) Conservation Easement of The State of California per Instrument No. 05-2619760, Recorded October 31, 2005 O.R.
- (R5) Flood Control Easement of Los Angeles County Flood Control District per Instrument No. 03-1793301, Recorded June 23, 2003 O.R.
- (R6) Slope Easement of The County of Los Angeles per Instrument No. 03-1793302, Recorded June 23, 2003 O.R.

# PSOMAS

**EXHIBIT C**  
**WEST CREEK PARK QUITCLAIM DEED– COUNTY OF LOS ANGELES TO CITY OF SANTA CLARITA**

RECORDING REQUESTED BY  
County of Los Angeles  
AND MAIL TO  
City of Santa Clarita  
23920 Valencia Boulevard  
Santa Clarita, CA 91355  
Attention: Ken Pulskamp

\*  
\*  
\*  
\*  
\*  
\*  
\*  
\*

\_\_\_\_\_ Space above this line for Recorder's use \_\_\_\_\_

THIS DOCUMENT IS EXEMPT FROM RECORDING FEES PURSUANT TO SECTION 27383 OF THE GOVERNMENT CODE  
THIS DOCUMENT IS EXEMPT FROM DOCUMENTARY TRANSFER TAX PURSUANT TO SECTION 11922 OF THE REVENUE AND TAXATION CODE

TAX PARCELS: 2810-105-900, 2810-110-901

# QUITCLAIM DEED

The **COUNTY OF LOS ANGELES, a body corporate and politic ("County")**, on a gratis basis, and in exchange for Grantee's agreement to comply with the provisions outlined in section b, c, d and e below, does hereby surrender, quitclaim and release to:

**CITY OF SANTA CLARITA, a municipal corporation ("Grantee")**,

all of the County's right, title and interest in and to the described real property, ("Property") reserving and excepting to the County all oil, gas, hydrocarbons, and other minerals in and under the Property without the right to the use of the surface or subsurface to a depth of 500 feet, measured vertically from the surface of the Property.

The Property is located in the City of Santa Clarita, County of Los Angeles, State of California, and is further described in Exhibit A, which is incorporated herein by reference as though set forth in full. The location of the Property is identified in the map attached hereto as Exhibit B, which is incorporated by reference as though set forth in full.



SUBJECT TO AND GRANTEE TO ASSUME:

- a. All taxes, interest, penalties and assessments of record, if any.
- b. Covenants, conditions, restrictions, reservations, easements, rights, and rights-of-way of record, if any.
- c. the condition that the Property is to be used for open space, public recreation and park purposes only;
- d. the condition that the Property shall be equally open and available to residents of incorporated and unincorporated territory, and there shall be no discrimination against or preference, gratuity, bonus or other benefits given to residents of incorporated area not equally accorded residents of unincorporated territory;
- e. the condition that in the event that County of Los Angeles determines that the owner in possession is not complying with these restrictions, then all right, title, and interest in and to the Property shall revert back to the County of Los Angeles upon providing a thirty (30) day notice to owner in possession of its failure to comply with these restrictions and without any necessity of any other affirmative action on the part of the County of Los Angeles.

Dated \_\_\_\_\_

COUNTY OF LOS ANGELES

COLA LOG NO. \_\_\_\_\_

By \_\_\_\_\_

Hilda L. Solis  
Chairman, Board of Supervisors

STATE OF CALIFORNIA                    )  
  ) ss.  
COUNTY OF LOS ANGELES            )

On January 6, 1987, the Board of Supervisors for the County of Los Angeles and ex officio the governing body of all other special assessment and taxing districts, agencies and authorities for which said Board so acts adopted a resolution pursuant to Section 25103 of the Government Code, which authorized the use of facsimile signatures of the Chairperson of the Board on all papers, documents, or instruments requiring said signature.

The undersigned hereby certifies that on this \_\_\_\_\_ day of \_\_\_\_\_, 2016, the facsimile signature of \_\_\_\_\_, Chair, Board of Supervisors, Los Angeles County was affixed hereto as the official execution of this document. The undersigned further certifies that on this date, a copy of the document was delivered to the Chairperson of the Board of Supervisors of the County of Los Angeles.

In witness whereof, I have also hereunto set my hand and affixed my official seal the day and year above written.

LORI GLASGOW, Executive Officer-Clerk of the  
Board of Supervisors, County of Los Angeles

By \_\_\_\_\_

**APPROVED AS TO FORM:**

MARY C. WICKHAM  
County Counsel

By: \_\_\_\_\_  
Deputy

EXHIBIT A TO QUITCLAIM DEED  
LEGAL DESCRIPTION

That certain real property situated in the State of California, County of Los Angeles, and described as follows:

Lots 367 and 391 of Tract No. 52455-01, in the County of Los Angeles, State of California, as per map recorded in Book 1323, Pages 43 to 73 inclusive of Map, in the Office of the County Recorder of said County.

**EXHIBIT D**

**RECORDING REQUESTED BY AND  
WHEN RECORDED MAIL TO:**

County of Los Angeles  
Real Estate Division  
Los Angeles, CA 90012  
222 South Hill Street, 3<sup>rd</sup> Floor  
Attn: Christopher M. Montana,  
Director of Real Estate Division

---

SPACE ABOVE THIS LINE FOR RECORDER'S USE

THIS DOCUMENT IS EXEMPT FROM RECORDING FEES PURSUANT TO SECTION 27383 OF THE GOVERNMENT CODE

THIS DOCUMENT IS EXEMPT FROM DOCUMENTARY TRANSFER TAX PURSUANT TO SECTION 11922 OF THE REVENUE AND TAXATION CODE

ASSESSOR PARCEL NUMBER: 2810-001-275

# **PARK EASEMENT QUITCLAIM DEED**

FOR GOOD AND VALUABLE CONSIDERATION, receipt of which is hereby acknowledged, the COUNTY OF LOS ANGELES, a body corporate and politic ("Grantor") does hereby surrender, remise, release, and forever quitclaim to the Metropolitan Water District of Southern California, a public corporation, all of its right, title, interest, and claim in and under that certain Permanent Easement Deed for purposes of a park. Said Permanent Easement Deed was originally granted to Newhall Land and Farming Company, a California Limited Partnership on June 12, 2007 and recorded on June 15, 2007, as Instrument Number 20071449775 in the Official Records of the County Recorder of Los Angeles County more particularly described in Exhibit "A" attached hereto and incorporated herein by this reference. Said rights of that Permanent Easement Deed were subsequently assigned to the County of Los Angeles through an Assignment Agreement dated January 11, 2010 and recorded January 14, 2010 as Instrument No. 0059020 in the Official Records of the County Recorder of Los Angeles County more particularly described in Exhibit "B" attached hereto and incorporated herein by this reference.

Signature Page Follows Immediately

IN WITNESS WHEREOF, the Grantor has executed this deed as of the date written below.

Dated: \_\_\_\_\_, 2016

**Grantor:**

COUNTY OF LOS ANGELES

By: \_\_\_\_\_  
SACHI A. HAMAI  
CHIEF EXECUTIVE OFFICER

APPROVED AS TO FORM

MARY C. WICKHAM  
County Counsel

By \_\_\_\_\_  
Deputy

EXHIBIT A – PERMANENT EASEMENT DEED GRANT TO NEWHALL

EXHIBIT B – ASSIGNMENT AGREEMENT TO COUNTY OF LA

**EXHIBIT F**

**RECORDING REQUESTED BY AND  
WHEN RECORDED MAIL TO:**

County of Los Angeles  
Real Estate Division  
Los Angeles, CA 90012  
222 South Hill Street, 3<sup>rd</sup> Floor  
Attn: Christopher M. Montana,  
Director of Real Estate Division

---

SPACE ABOVE THIS LINE FOR RECORDER'S USE

THIS DOCUMENT IS EXEMPT FROM RECORDING FEES PURSUANT TO SECTION 27383 OF THE GOVERNMENT CODE

THIS DOCUMENT IS EXEMPT FROM DOCUMENTARY TRANSFER TAX PURSUANT TO SECTION 11922 OF THE REVENUE AND TAXATION CODE

ASSESSOR PARCEL NUMBERS:  
2810-002-088, 2802-109 AND 015,  
2810-110-012, 2810-111-004

# BIKE TRAIL EASEMENT QUITCLAIM DEED

FOR GOOD AND VALUABLE CONSIDERATION, receipt of which is hereby acknowledged, the COUNTY OF LOS ANGELES, a body corporate and politic ("Grantor") does hereby surrender, remise, release, and forever quitclaim to NEWHALL LAND AND FARMING, a California Limited partnership all of its right, title, interest, and claim in and under that certain Grant of Easement for a paved trail and associated improvement for public recreational uses. Said Grant of Easement was originally granted to the County of Los Angeles on June 3, 2011 and recorded on June 31, 2011, as Instrument Number 20110481496 in the Official Records of the County Recorder of Los Angeles County more particularly described in Exhibit "A" attached hereto and incorporated herein by this reference.

Signature Page Follows Immediately

IN WITNESS WHEREOF, the Grantor has executed this deed as of the date written below.

Dated: \_\_\_\_\_, 2016

**Grantor:**

COUNTY OF LOS ANGELES

By: \_\_\_\_\_  
SACHI A. HAMAI  
CHIEF EXECUTIVE OFFICER

APPROVED AS TO FORM

MARY C. WICKHAM  
County Counsel

By \_\_\_\_\_  
Deputy



EXHIBIT A – GRANT OF EASEMENT FROM NEWHALL TO COUNTY OF LA

**EXHIBIT H**

**CITY OF SANTA CLARITA CERTIFICATE OF ACCEPTANCE**

This is to certify that the attached interest in real property conveyed by the Quitclaim Deeds dated \_\_\_\_\_2016, by the COUNTY OF LOS ANGELES, a body corporate and politic, to the CITY OF SANTA CLARITA, a municipal corporation and/or government agency, is hereby accepted by the undersigned officer or agent on behalf of the City Council of the City of Santa Clarita pursuant to authority conferred by Resolution No. 88-119, of the City Council of the City of Santa Clarita adopted on August 25, 1988, and the grantee consents to the recordation thereof by its duly authorized officer.

Dated: \_\_\_\_\_

By: \_\_\_\_\_

Approved as to Form:

By: \_\_\_\_\_  
City Attorney

Dated: \_\_\_\_\_